

STANDARD BIDDING DOCUMENTS



GUYANA POWER AND LIGHT INC

Procurement of Goods

IFB # GPL- PD - 002- 2022

Supply of:

**20 and 35 MVA ONAN Rated Three Phase Power Transformers &
35 MVA Mobile Substation**

January 2022

Closing Date: February 03, 2022 @ 14:00 hrs or 2:00pm

Bid Opening: February 03, 2022 @ 14:30 hrs or 2:30pm

Invitation for Bids (IFB)

Cooperative Republic of Guyana

IFB# GPL - PD – 002 - 2022

The Guyana Power and Light Incorporated (GPL) invite sealed bids from eligible bidders for the supply of **20 and 35 MVA ONAN Rated Three Phase Power Transformers & 35 MVA Mobile Substation**

A bid Security of 2 % of the tendered sum must be submitted along with the bid.

Bids shall be valid for 90 days after the date of bid opening.

Bids must be submitted via email to our electronic tender box: gpltenderbox@gplinc.com

- Bids must be submitted with a valid **National Insurance (NIS) & Guyana Revenue Authority (GRA) Compliance Certificate**

Deadline for submission of bids is 14:00 hrs. (2:00 p.m.) on, **February 03, 2022**.

Bid opening is scheduled for 14:30 hrs (2:30 pm) on **February 03, 2022** at GPL's Board Room 91 Duke Street, Kingston, Georgetown, Guyana via Zoom call in the presence of Bidders/ Representatives who may choose to participate.

IMPORTANT: Bidders downloading the bid document are advised to forward a registration E-mail to kwilson@gplinc.com , gpersaud@gplinc.com or proc_mng_sect@gplinc.com stating the following: Name of Bidder, Address, Contact No and Email address.

The above information will be used to inform bidders of any amendments to the bidding document and also to forward all responses to queries.

GPL reserves the right to reject any or all bids.

CONTENTS

Invitation For Bids (IFB)	2
Instruction To Bidders (ITB)	4
Bid Data Sheet (BDS)	10
General Conditions of Contract (GCC)	12
Special Conditions of Contract (SCC)	16
Schedule of Requirements/ Technical Specs	19
Bid Delivery Schedule	90
Qualification Information	91
Supplier's Bid	93
Supply Contract	94
Bid Security	96
Bid Securing Declaration	97
Manufacturer's Authorization	98
Performance Security	99
Letter of Acceptance	100
Power of Attorney	101
Evaluation and Qualification Criteria	102

INSTRUCTIONS TO BIDDERS

A. Introduction

1. Description of the Procurement

The Procuring Entity is Guyana Power and Light Inc. that intends to procure the goods identified in the *Bid Data Sheet* and in the Schedule of Requirements.

2. Eligibility and qualifications of Bidders

- 2.1 In order to be awarded a procurement contract, Bidders should possess the technical and financial capacity needed to perform the contract. They should fulfill their tax and national insurance fund liabilities in Guyana and should not currently be subjected to a debarment penalty and must comply with the specific eligibility and qualification requirements referred to in the *Bid Data Sheet*. Bidders shall provide the information and any supporting documentation required by the Qualification Information Form.
- 2.2 The bidders should not have a conflict of interests, including involvement in more than one bid in this proceeding, should not be associated nor have been associated in the past, directly or indirectly, with any agency or any of its representative, affiliate, that have been engaged by the Procuring Entity to provide consulting services at the preparation stage of the bidding documents, technical specifications and other documentation that are subject to be used in the procurement of goods, which must be purchased in accordance with the Invitation for Bids. In cases where the indicated facts are discovered, the Bidder's bid shall be rejected.

B. Bidding Documents

3. Clarification and amendment of bidding Documents

- 3.1 The Procuring Entity in not more than three (3) working days, will respond in writing (including by fax or electronic mail) to any request for clarification of the bidding documents to be received (in writing, including by fax or electronic mail) not later than 10 days before the expiry of a deadline for submission of bids. At the same time, the Procuring Entity's response shall without identifying its source of the request, be distributed to all bidders who have received the bidding documents from the Procuring Entity.
- 3.2 At any time before the deadline for submission of bids, the Procuring Entity may amend the bidding documents by issuing an Addendum and notifying it to the prospective bidders.

C. Preparation of Bid

4. Language of Bid

- 4.1 The bid prepared by the Bidder, as well as all correspondence and documents related to that bid and exchanged by the Bidder and the Procuring Entity shall be written in the language specified in the *Bid Data Sheet*.

5. Documents Included in Bid

5.1 The bid prepared by the Bidder should contain the Form of Bid, the Price Schedules and the other documents to be submitted in accordance with these Instructions to Bidders.

6. Bid Price

6.1. Subject to the choice of INCOTERMS as indicated in the Bid Data Sheet, the prices given in the Price Schedule shall include all transportation costs to the destination point indicated in the Contract, all taxes, duties, payments collected, in accordance with the laws of Guyana and delivery related and other costs on performing of contractual obligations.

6.2. The prices offered by the Bidders shall remain fixed during the whole period of Contract performance and shall not be modified in any circumstance.

7. Bid and Payment Currency

7.1 The prices shall be indicated in UK Pounds, US Dollars and Euros for Foreign Suppliers and Guyana Dollars for Domestic Suppliers, unless otherwise specified in the *Bid Data Sheet*.

8. Bid Security / Bid Securing Declaration

8.1 Unless otherwise provided in the *Bid Data Sheet*, the Bidder shall furnish, as part of his bid, a Bid Security, in the form, currency and amount specified in the *Bid Data Sheet* with a validity period for not less than 2 weeks upon the expiry of the bid validity period and in line with the form provided, or, if so indicated in the BDS, a Bid Securing Declaration in accordance with the form provided. **A Bid Securing Declaration is not required.**

8.2 The bid security may be forfeited, or the Bid Securing Declaration executed, if the Bidder:

- (a) withdraws his/her bid after it is opened during the period of validity specified in the bid; or,
- (b) Having been awarded the contract fails:
 - (1) To sign the contract on the terms and conditions provided in his bid; or
 - (2) To furnish the Performance Security, if required to do so.

9. Period of Validity of Bid

9.1 Bids shall remain in force during the period specified in *the Bid Data Sheet* after the date of bid opening.

10. Deadline for Submission of Bids

10.1 Bids must be received by the Procuring Entity at the address and within the periods specified in *the Bid Data Sheet*. All bids received by the Procuring Entity upon the expiry of a period established for submission of bids as indicated by the Procuring Entity shall be rejected and returned to the Bidder unopened.

11. Modification and Withdrawal of Bids

- 11.1 The Bidder may modify or withdraw his bid after the bid's submission, provided that the Procuring Entity will receive a written notice of modification, including substitution or withdrawal of bid until the expiry of established period for submission of bids.

E. Opening and Evaluation of Bids

12. Opening of Bids

- 12.1 The Procuring Entity will open all bids in the presence of bidders' representatives who wish to attend, at the time, on the date, and at the address specified in the *Bid Data Sheet*. The bidders' representatives who are present shall sign a register evidencing their attendance.
- 12.2 The bidders' names, bid prices, including alternatives (if alternatives permitted), information on the presence or absence of required bid security, or bid securing declaration, information on the presence (absence) of tax debts and debts of social insurance payments will be announced at the opening. No bid may be rejected at the opening, exclusive of late bids to be returned to the Bidder unopened.
- 12.3 Bids (and modifications sent pursuant to ITB Clause 12.2 that are not opened and read out during the bid opening shall not be accepted for further evaluation, regardless of circumstances.

13. Evaluation of Bids

- 13.1 During the evaluation of bids, the Procuring Entity may, at his discretion, request the Bidder to provide clarification of his bid. The request for clarification and the response thereto shall be made in writing, and in that case no change in price or substance of the bid shall be sought, offered, or permitted.
- 13.2 The Procuring Entity shall determine the responsiveness of each bid to requirements of the bidding documents. For the purposes of this Clause a substantially responsive bid is one which satisfies all the indicated provisions without a material deviation or reservation.
- 13.3 The Procuring Entity may waive any minor nonconformity or small mistake or inaccuracy in the bid, which is not a material deviation from the requirements of the bidding documents, and such non-conformity or inaccuracy will not affect the bid evaluation. To the extent feasible and appropriate, for the purposes of comparing bids, acceptable deviations shall be quantified in monetary terms and reflected in adjustments to the bid price (for the purposes only of comparison of bids).
- 13.4 Arithmetical errors shall be rectified in the following manner: if there is a discrepancy between the unit price and the total price that is obtained by multiplying the unit price and quantity, the unit price shall prevail, and the total price shall be corrected. If there is a discrepancy between words and figures, the sum in words shall be preferable. If the Bidder disagrees with such correction of errors, his/her bid shall be rejected.

- 13.5 The Procuring Entity shall evaluate and compare only the bids that are determined to be responsive to the bidding documents.
- 13.6 The methodology to adjust the price to reflect the price of the missing or non-conforming item or component is the average price of the item of all responsive bids.

14. Confidentiality and Contacting the Procuring Entity

- 14.1 No Bidder shall contact the Procuring Entity on any matter related to his/her bid from the date of bid opening until the date of contract award, except for requests related to clarification of the bid. Information concerning the evaluation of bids is confidential.
- 14.2 Any effort by the Bidder to influence the Procuring Entity's decision on bid evaluation and comparison, or contract award may result in the rejection of that Bidder's bid.

F. Award of Contract

15. Award Criteria

- 15.1 Subject to ITB Clause 18, the Procuring Entity will award the Contract to the Bidder whose bid is determined to be substantially responsive to the requirements of the bidding documents, and who offered **the Lowest Evaluated Bid**, provided that the Bidder has been determined:
- (a) to be eligible pursuant to Clause 2;
 - (b) to comply with qualification requirements, in accordance with Clause 2, and any technical requirements and technical evaluation criteria disclosed in the bidding documents.

16. Procuring Entity's Right to Vary Quantities at Time of Entering into a Contract

- 16.1 The Procuring Entity reserves the right, when entering into a contract, to increase or decrease the quantity of goods and related services specified in the Schedule of Requirements, by the percentage indicated in the *Bid Data Sheet*, no change in the unit price or other conditions shall be made (an increase of quantity not exceeding 10 percent variation).

17. Procuring Entity's Right to Accept Any Bid and to reject All Bids

- 17.1 The Procuring Entity reserves the right to accept or reject any bid or all bids, and to cancel the bidding process at any time prior to award of contract, without thereby incurring any liability to Bidders and without being required to inform the Bidder or Bidders of reasons of such actions.

18. Notification of Award

- 18.1. The bidder whose bid is accepted will be notified of the award of contract by the Purchaser prior to expiration of the quotation validity period.
- 18.2. The notice of acceptance shall be equal to entering into a Contract, provided that the Bidder furnishes the performance security and the signed Contract.
- 18.3. At the same time that the Procuring Entity notifies the successful Bidder in accordance with sub-clause (1), the Procuring Entity will notify all other Bidders of the name of successful

Bidder, and his bid price.

18.4 The evaluation report and comparison of bids will not be sent to bidders.

19. Signing of Contract and performance security

19.1 At the same time with notification of award, the Procuring Entity will send the successful Bidder the Form of Contract contained in the bidding documents. The successful Bidder shall sign and date the Contract, and return it to the Procuring Entity during seven (7) days of receipt of notice of award.

19.2 Together with the signed Contract, the Bidder shall, if required to do so by the *Bid Data Sheet*, furnish the Procuring Entity with a Performance Security in the amount and form specified in the *Bid Data Sheet*.

19.3 If the successful Bidder fails to furnish the performance security, if required to do so, or during 14 (fourteen) days fails to return the Contract signed by him, then it shall be a sufficient ground to refuse the award of Contract, and to forfeit the bid security, or execute the bid-securing declaration. In that case the Procuring Entity shall award the Contract to the next lowest evaluated Bidder, subject to the right of the Procuring Entity to reject all bids.

20. Settlement of disputes

20.1 To settle the disputes, which may arise during the execution of the Contract, the parties shall follow the procedure referred to in the *Bid Data Sheet*.

21. Corrupt and Fraudulent Practices

21.1 The Procuring Entity requires that Bidders observe the highest standards of ethics during the procurement and execution of such contracts. In pursuance of this policy, the Procuring Entity:

(a) will reject the bid if it establishes that the Bidder recommended for award has engaged in corrupt, fraudulent, collusive, or coercive practices in competing for the Contract in question;

(b) will declare the Supplier, for indefinite or specified period of time, to be ineligible to participate in state-financed biddings, in accordance with applicable debarment procedures.

22. Compliances

22.1 Bidder registered in Guyana must submit valid certificates of compliances from Guyana Revenue Authority (GRA), National Insurance Scheme (NIS), and (VAT registration is required only if item being supplied is Vatable).

23. Defects Liability:

23.1 The “Defects Liability Period” for the goods and related services is twelve (12) months from the date of taking over possession or such other period as may be specified in the Bid Data Sheet. During this period, the supplier will be responsible for replacing any defective item free of cost to the Procuring Entity.

24. Inspection and Testing

24.1 The Supplier shall at its own expense and at no cost to the Purchaser carry out all testing and/or inspections of the Goods and Related Services as are specified in the Technical Specification. Whenever the Supplier is ready to carry out any such test and inspection, it shall give a reasonable advance notice, including the place and time, to the Purchaser.

The Supplier shall obtain from any relevant third party or manufacturer any necessary permission or consent to enable the Purchaser or its designated representative to attend the test and/or inspection.

24.2 The Purchaser may require the Supplier to carry out any test and/or inspection not required by the Contract but deemed necessary to verify that the characteristics and performance of the Goods comply with the technical specifications codes and standards under the Contract.

24.3 The Supplier shall provide the Purchaser with a report of the results of any such test and/or inspection.

24.4 The Purchaser may reject any Goods or any part thereof that fail to pass any test and/or inspection or do not conform to the specifications. The Supplier shall either rectify or replace such rejected Goods or parts thereof or make alterations necessary to meet the specifications at no cost to the Purchaser, and shall repeat the test and/or inspection, at no cost to the Purchaser, upon giving a notice.

24.5 The Supplier agrees that neither the execution of a test and/or inspection of the Goods or any part thereof, nor the attendance by the Purchaser or its representative, nor the issue of any report, shall release the Supplier from any warranties or other obligations under the Contract.

Bid Data Sheet (BDS)

The following specific data to clauses of the provisions of Instructions to Bidders which supplement, or amend the provisions of the Instructions to Bidders (ITB) whenever there is a conflict, the provisions herein shall prevail over those in ITB

Item No.	
ITB 1.1	Guyana Power and Light Inc. of 40 Main Street Georgetown Guyana Telephone #592-226-9598 Email: kwilson@gplinc.com or gpersaud@gplinc.com The subject of the procurement is: The Supply of 20 and 35 MVA ONAN Rated Three Phase Power Transformers & 35 MVA Mobile Substation
ITB 2.1	To qualify for award of the Contract, the bidders shall provide satisfactory evidence to the Purchaser of their capability and adequacy of resources to carry out the Contract effectively: <ul style="list-style-type: none"> (a) Copies of original documents defining the constitution or legal status, place of registration and principal place of business. (b) Experience as a supplier in carrying out of 2 (two) or more supplies of a similar items within the last 3 (three) years. (c) Average Turnover for the last three years should be a least US\$ 400,000.00. (d) Evidence of access to lines of credit and availability of other financial resources. (e) Evidence compliance with NIS, GRA, Vat registration if applicable (Only applies to local Supplier). (f) To be covered by an express warranty period of twelve (12) month. (g) Manufacturers authorization form. (h) Wherever practicable sample(s) may accompany a bid. GPL Inc. reserves the right to request sample(s) before the awarding of a tender.
ITB 4.1	Language of Bid shall be English
ITB 5.1	Other documents to be submitted includes; GRA and NIS Compliances, (TIN Certificate and VAT Registration if the item/s being procured attract VAT). Only applies to suppliers who are registered office is within Guyana
ITB 6.1	The price quoted by bidders shall be on the basis of CIF for goods delivered from abroad and for goods delivered from within Guyana. Incoterms 2010 shall apply.
ITB 7.1(a)	For Goods and Related Services with origin in the Purchaser's country, the currency of the bid shall be Guyana Dollars (GY\$) (Suppliers with registered

<p>ITB 7.1(b)</p> <p>ITB 7.1(c)</p>	<p>business in Guyana must submit their bid in Guyana Dollars (GY\$).</p> <p>For Suppliers outside of the Purchaser’s country the currency of the bid can be US\$,GBP or a freely convertible currency.</p> <p>The currency that will be used for bid evaluation and comparison purposes to convert all bid prices expressed in various currencies into a single currency is the Guyana Dollars G\$.</p> <p>The source of exchange rate shall be the Bank of Guyana, and the selling rate shall be used.</p> <p>The date for exchange rate shall be ten days before the opening of tenders.</p>
<p>ITB 8.1</p>	<p>A bid security of 2% of the tendered sum is required. A signed Bid Securing Declaration is not required.</p>
<p>ITB 9.1</p>	<p>The period of validity of bid is 90 Days.</p>
<p>ITB 11.1</p>	<p>Deadline and place for submission of bids: 14:00 hours on <u>February 03, 2022.</u> Attention: Secretary to the Tender Board, Guyana Power and Light, Inc. 91 Duke Street, Kingston Georgetown Guyana South America.</p>
<p>ITB 13.1</p>	<p>Time and place for opening of bid: The Board Room, Guyana Power and Light, Inc., 91 Duke Street, Kingston, Georgetown, Guyana, South America.</p>
<p>ITB 17.1</p>	<p>When entering into a contract the Procuring Entity reserves the right to Increase or decrease quantities of goods by 10%.</p>
<p>ITB 20.2</p>	<p>The performance security shall be 10% of the Contract Price and in the form of a Bank Guarantee or Managers Cheque.</p>
<p>ITB 21.1</p>	<p>Disputes that may arise in the performance of the contract shall be settled in accordance with the Procurement Act 2003.</p>
<p>ITB 24.1</p>	<p>The duration of the defects liability period is to be stated by the Bidder.</p>

General Conditions of Contract (GCC)

The General Conditions are the Standard General Conditions of Contract. No alteration shall be made on the pages of these Conditions. The Procuring Entity, when amending or supplementing the General Conditions of Contract should do so only in the Special Conditions of Contract. Any amendment or addenda of the General Conditions of Contract shall conform to the legislation of Guyana.

1. Definitions and application

1.1 This Contract lists below the terms that have the following interpretation:

- (a) **“Contract”** means the agreement entered into between the Procuring Entity and the Supplier, as recorded in the Form of Contract signed by the parties, including all attachments and appendices thereto and all the documents referenced therein;
- (b) **“Contract Price”** means the price payable to the Supplier under the Contract for complete and proper performance of his contractual obligations;
- (c) **"Goods"** means the item(s) referred to in the SCC;
- (d) **«GCC»** - means the General Conditions of Contract contained in this Section;
- (e) **"SCC»** - means the Special Conditions of Contract;
- (f) **"Procuring Entity"** – means the Procuring entity carrying out the procurement of Goods, specified in the SCC;
- (g) **"Supplier"** – means an individual or legal entity, or a combination of any above mentioned forms which operate under the existing agreement as a joint venture and supply the Goods and Services under the Contract;
- (h) **"Day"** – means calendar day.

1.2 The General Conditions of Contract shall apply in the procurement of goods; the specific amendment, addition and alteration shall be indicated in the Special Conditions of Contract.

1.3 Warrant requirements are as may be specified in the special conditions of contract.

2. Contract Documents

2.1 Subject to the order of precedence set forth in the Contract Agreement, all documents forming the Contract (and all parts thereof) are intended to be correlative, complementary, and mutually explanatory. The contract shall be read as a whole.

3. Performance Security

- 3.1 If required by the SCC, during fourteen (14) days of receipt of notification of award, the successful Bidder shall furnish the Procuring Entity with the performance security the amount and form of which are indicated in the SCC.

4. Packing

- 4.1 The Supplier shall provide such packing of the Goods as is required to prevent their damage or deterioration during transit to final destination specified in the Contract, and as may be required by the Special Conditions of Contract.

5. Delivery, Transportation, Mobilization Advance

- 5.1 The Supplier must deliver the Goods within the periods and to the Destination point indicated in the Schedule of Requirements and shall provide the documentation indicated in the SCC. Subject to the SCC, transportation of the Goods to the place specified by the Procuring Entity shall be carried out and paid by the Supplier, and related costs shall be included in the Contract Price.

6. Payment

- 6.1 The payment to the Supplier for the Goods delivered shall be made in accordance with the Contract in the form and within the periods specified in the SCC.

7. Prices

- 7.1 Prices established by the Supplier in the Contract for goods delivered shall not vary from the prices quoted by the Supplier in his bid.

8. Assignment

- 8.1 The Supplier shall not assign, in whole or in part, his obligations under the Contract to the third party for the execution without the Procuring Entity's prior written consent.

9. Delays in the Supplier's Performance and liquidated damages

- 9.1 Delivery of the Goods shall be carried out by the Supplier, in accordance with the schedule indicated by the Procuring Entity in the *Delivery Schedule*.
- 9.2 Except for provided under GCC Clause 13, the delay in the Supplier's performance of his delivery obligations shall render the Supplier liable for payment of liquidated damages in the amount specified in the SCC, unless an extension of time is agreed upon by the parties without application of liquidated damages. Once the maximum deduction specified in the SCC is reached, the Procuring Entity may consider termination of the Contract, in accordance with Clause 10 of the General Conditions of Contract.

10. Termination

- 10.1 The Procuring Entity, without detriment to any other sanctions of infringement of the provisions of Contract, by written notice of default sent to the Supplier, may terminate this Contract in whole or in part:
- (a) If the Supplier fails to deliver the portion or all of the Goods within the periods provided for in the Contract, or within an extension period of that Contract, or to perform any of his obligations under the Contract;
 - (b) If bankruptcy procedures are applied to the Supplier, or it is declared insolvent.
 - (c) If the Supplier, in the Procuring Entity's opinion, has engaged in corrupt, fraudulent, collusive or coercive practices when entering into or executing the Contract;
 - (d) If the Procuring Entity deems that continued implementation of the contract would no longer be expedient from the standpoint of the public interest
- 10.2 The notice of termination shall specify the reason of termination, the extent to which performance of the Supplier under the Contract is terminated, and the date upon which such termination becomes effective.
- 10.3 Notwithstanding clauses 9 and 10.1, the Supplier shall not forfeit his performance security, and shall not be liable for payment of liquidated damages, or termination for default, if delay in executing the Contract or failure to perform obligations under the Contract is the result of an event of force majeure. When force majeure arises, the Supplier shall promptly notify the Procuring Entity in writing of such circumstance and its causes.
- 10.4 When the contract is terminated in accordance with clause 10.1(d), the Goods that are complete and ready for shipment within twenty-eight (28) days after the Supplier's receipt of notice of termination shall be accepted by the Procuring Entity at the Contract terms and prices. For the remaining Goods, the Procuring Entity may elect:
- (a) to have any portion completed and delivered at the Contract terms and prices; and/or
 - (b) to cancel the remainder and pay to the Supplier an agreed amount for partially completed Goods and Related Services and for materials and parts previously procured by the Supplier.

11. Settlement of Disputes

- 11.1 If any dispute or disagreement arises between the Procuring Entity and the Supplier for the Contract or in connection with it, the parties shall make every effort to resolve the dispute or disagreement amicably by mutual consultation.
- 11.2 If during twenty one (21) days, the parties failed to resolve their dispute or disagreement by mutual consultation; either the Procuring Entity or the Supplier may send the other party the notice of intent to commence arbitration, if an arbitration is incorporated in the Contract in the Special Conditions of Contract or otherwise agreed by the parties, or in the

Court of General Jurisdiction if no arbitration is envisaged, and no arbitration or litigation in respect of that matter may be commenced unless such notice is given.

Any dispute or disagreement in respect of which the notice of intent is sent to commence trial shall be heard by the [Court of General Jurisdiction].

- 11.3 Notwithstanding any reference to dispute settlement herein, the parties shall continue to perform their obligations under the Contract, unless they agree otherwise.

12. Applicable Law

- 12.1 The Contract shall be interpreted in accordance with the laws of Guyana.

13. Formal Communication between the Procuring Entity and the Supplier

- 13.1 Any notice given by one party to the other pursuant to the Contract shall be in force if it is done in writing and sent at the address of other party in the SCC.

- 13.2 A notice shall be effective when delivered or on the specified date, whichever is later.

14. Taxes and Duties

- 14.1 The Supplier shall be fully responsible for all taxes, duties, license taxes, etc., levied in accordance with the legislation of Guyana, and subject to the application of INCOTERMS in accordance with the SCC.

15. Retention

- 15.1 No retention shall be applied on consumables, but warranties, guarantees and expiry dates to apply.

Special Conditions of Contract (SCC)

The following Special Conditions of Contract shall supplement the General Conditions of Contract. Whenever there is a conflict, the provisions herein shall prevail over those in the General Conditions of Contract.

GCC Clause No.	Special Conditions of Contract
<p>1</p> <p>1.1 (f)</p> <p>1.1 (g)</p> <p>1.1(c)</p>	<p>Definitions</p> <p>The Procuring Entity is Guyana Power and Light of 40 Main Street Georgetown Guyana South America, Tele #592-226-9598, <i>Fa x# 592 227-2180 Email: ajohnson@gplinc.com</i></p> <p>The Supplier is Not Applicable <i>(indicate full name, legal address, phone, fax and e-mail of Supplier)</i></p> <p>The Subject of procurement is The Supply of 20 and 35 MVA ONAN Rated Three Phase Power Transformers & 35 MVA Mobile Substation</p>
<p>3.1</p>	<p>A Performance Security will be required Fourteen (14) days after receipt of notification award in the amount and form of a Bank Guarantee or Managers Cheque not exceed ten (10) percent of the Contract price.</p>
<p>4.1</p>	<p>Packing The packing, marking and documentation within and outside the packages shall be:</p> <p><u>Packing</u></p> <p>The Supplier shall provide such packing of the Goods as is required to prevent their damage or deterioration during transit to their final destination, as indicated in the Contract. The packing shall be sufficient to withstand, without limitation, rough handling during transit and exposure to extreme temperatures, salt and precipitation during transit, and open storage. Packing case size and weights shall take into consideration, where appropriate, the remoteness of the Goods' final destination and the absence of heavy handling facilities at all points in transit.</p> <p><u>Marking</u> Marking shall be in accordance with international practice and shall be agreed with the Purchaser. The Goods shall be addressed for delivery to Guyana Power & Light, 40 Main Street, Georgetown, Guyana, South America.</p>
<p>5.1</p>	<p>Delivery, Transportation</p> <p><u>Documentation</u></p> <p>(a) For Imported Goods.</p> <p>Within 24 hours of shipment, the Supplier shall notify the Purchaser and the Insurance Company by cable or telex or fax, the full details of the shipment including Contract number, description of Goods, quantity, the vessel, the bill of lading number and date, port of loading, date of shipment, port of discharge, etc.</p>

The Supplier shall mail the following Original documents to the Purchaser with a copy to the insurance Company:

- (1) Supplier's invoice indicating a description, quantity, unit price of the Goods and sum total;
- (2) Shipping order, railway receipt or truck receipt;
- (3) Warranty certificate of Manufacturer or Supplier;
- (4) Inspection certificate issued by the authorized inspection service, and the supplier's factory inspection report (if any);
- (5) Certificate of origin;
- (6) Certificate of conformity;
- (7) Full set of ocean on-board bills of lading, of air waybills or courier/parcel post Certificates consigned to the Purchaser;
- (8) Packing list identifying contents of each package, and clearly showing Shipping marks and package numbers, kind of package, contents, dimensions and Gross weights of each package in pounds or kilos.

The above documents shall be received by the Purchaser at least two (2) weeks before arrival of Goods at the port or place of arrival and, if not received, the Supplier will be responsible for any consequent expenses.

6.1

Payment

The method and conditions of payment to be made to the Supplier under this Contract shall be as follows:

Payment for Goods supplied:

Payment will be as follows:

Advance Payment:

Thirty (30) percent of the Contract Price shall be paid within thirty (30) days of signing of the Contract, and upon submission of claim and a bank guarantee for equivalent amount valid until the Goods are delivered and in the form provided in the bidding documents or another form acceptable to the Purchaser.

On Delivery:

Sixty (60) percent of the Contract Price of the Goods shipped shall be paid upon submission of claim and evidence that items are ready for shipment.

On Acceptance:

Ten (10) percent of the Contract Price of Goods received shall be paid within thirty (30) days of receipt of the Goods supported by the acceptance certificate issued by the

	Purchaser.
9.2	<p>Liquidated Damages The liquidated damage shall apply and they shall be equivalent to one percent (1%) of the delivered price of the delayed Goods or unperformed services per each day of delay or part thereof until actual delivery.</p> <p>The maximum amount of liquidated damages shall be: 10 percent (10 %) of the delayed Goods or services contract price.</p>
11.2	<p>Settlement of Disputes The rules of procedure for arbitration proceedings pursuant to GCC Sub-Clause 11.2 shall be as follows:</p> <p><i>(a) Contract with foreign Supplier:</i></p> <p>GCC 11.2 (a) Any dispute, controversy or claim arising out of or relating to this Contract, or breach, termination or invalidity thereof, shall be settled by arbitration in accordance with the UNCITRAL Arbitration Rules as at present in force.</p> <p><i>(b) Contracts with Supplier national of the Purchaser's country:</i></p> <p>In the case of a dispute between the Purchaser and a Supplier who is a national of the Purchaser's country, the dispute shall be referred to adjudication or arbitration in accordance with the laws of Guyana</p> <p>(c) The Courts of Georgetown, Guyana, shall have exclusive jurisdiction in all the matters arising in the contract including execution of Arbitration Awards</p>
12.1	The governing law shall be the law of: Guyana

Schedule of Requirements/ Technical Specs

IFB # GPL-PD-002-2022

Supply of: 20 and 35 MVA ONAN Rated Three Phase Power Transformers & 35 MVA Mobile Substation

Description	Quantity
35 MVA Mobile Substation	1
20 MVA Transformer	2
35 MVA Transformer	2

Technical Specifications for 35 MVA Mobile Substation

1. SCOPE

The design, manufacture, test, supply, delivery and warranty of mobile substations, rated up to 50MVA, generally conforming to IEEE C57.12.34, except as specified otherwise herein.

This specification is intended to supplement IEEE C57.12.34. Additional or modifying statements made in this document shall supersede applicable sections. Where no reference is made in this specification, IEEE C57.12.34 shall apply.

Materials will be evaluated to ensure conformity with submitted manufacturer's drawings/documentation and relevant standards as listed within this specification.

2. APPLICABLE STANDARDS

Except where modified by this specification, the transformers shall be designed, manufactured and tested in accordance with the latest editions of the following standards (Table 1). The proponent may propose alternative standards, but shall demonstrate that these give a degree of quality and performance equivalent to or better than the referenced standards herein.

Acceptability of an alternative standard is at the discretion of the Purchaser.

The Proponent shall furnish a copy of the alternative standard proposed along with the bid. If the alternative standard is not written in the English Language, a certified English Language translated version of the original standard shall be submitted with the bid.

Table 1: Applicable Standards

Item No.	ANSI/IEC Standards	Title
1	IEEE C57.154	IEEE Standard for the Design, Testing, and Application of Liquid-Immersed Distribution, Power, and Regulating Transformers Using High-Temperature Insulation Systems and Operating at Elevated Temperatures
2	IEEE C57.12.00	Standard General Requirements for Liquid-Immersed

		Distribution, Power, and Regulating Transformers
3	IEEE C57.12.29	Pad-Mounted Equipment— Enclosure Integrity for Coastal Environments
4	IEEE C57.12.70	IEEE Standard Terminal Markings and Connections for Distribution and Power Transformers
5	IEEE C57.12.90	Standard Test Code for Liquid-Immersed Distribution, Power, and Regulating Transformers Corrigendum 1:Editorial and Technical Corrections
6	IEEE C57.147	Guide for Acceptance and Maintenance of Natural Ester Fluids in Transformers
7	IEEE C62.11	IEEE Standard for Metal-Oxide Surge Arresters for AC Power Circuits (> 1 kV)
8	ASTM D3487	Standard Specification for Mineral Insulating Oil Used in Electrical Apparatus
9	NEMA TR 1	Transformers, Regulators, and Reactors
10	IEC 60076	Power Transformers

In case of conflict, the order of precedence shall be:

- This Technical Specification
- IEEE standards
- Other Applicable and Recognised Standards for pad mounted distribution transformers.

3. INSTALLATION/SERVICE CONDITIONS

The installation conditions of the transformers shall be as follows:

1. Maximum altitude above mean sea level less than 1,000 m;
2. Maximum ambient air temperature 40⁰C;
3. Maximum daily average ambient air temperature 30⁰C;
4. Minimum ambient temperature 15⁰C; and
5. Maximum relative humidity 100%.

All outdoor materials, components and equipment shall be designed and protected for use in exposed, heavily polluted and salty, corrosive and humid tropical coastal atmospheric conditions.

4. ELECTRICAL SYSTEM CONDITIONS

The transformer shall be suitable to be installed in GPL’s primary distribution system, which has the following characteristics (Table 2).

Table 2: Characteristics of GPL’s Primary Distribution System

Nominal System Voltage, Frequency and Phase	High Voltage (HV) Side	69 kV, 60 Hz, 3φ-3-wire
	Medium Voltage (MV) Side	13.8kV, 60 Hz, 3φ-3 wire
Voltage Class	72.5 kV	
Short circuit withstand Capability	As per IEEE C57.12.00, section 7.1.3	
Insulation Level		
Basic Insulation Level (BIL)	As per IEEE C57.12.00, Table 3	
Power Frequency withstand level – Dry 1 Minute	As per ANSI C57.12.00, Table 10 for 15 kV class and 140 kV for 69 kV class	
Power Frequency withstand level – Wet 10 Seconds		
System Grounding		
Neutral Grounding	High Side	High Side neutral of the substation transformer are switchable. In other words, it can be solidly grounded or not, depending on site requirements.
	Low Side	Grounded through distribution substation Zig-zag transformer with resistive neutral grounding.

5. MOBILE TRANSFORMER RATING

The transformers shall be double wound, sealed type, oil immersed with oil directed and air forced cooling (ODAF), three phase (3φ), mobile transformers with typical ratings from 10 MVA to 50MVA.

Cellulose insulation is acceptable for mobile transformers below 20MVA while Hybrid Nomex

insulation is required for transformers above 20MVA (as in this case).

The transformers are required to be equipped with four (4) HV and three (3) MV bushing terminations.

The design of the tank, fittings, bushings, etc., shall be such that it will not be necessary to keep the transformer energised to prevent deterioration as the transformers may be held in reserve and outdoors conditions for many years.

All transformers, inclusive of tap changer and other current carrying components, shall accept emergency overloading as per ANSI/IEEE C57.92, section 4.

6. TAPS AND VOLTAGE REGULATION

Transformers shall have the following voltage transformation ratio and tapping range:

- Voltage ratings shall be specified on the purchase order typically: 69,000 Y – 13,800 delta Volts
- tolerance on the voltage ratio shall be in accordance with IEEE C57.12.00, section 9.1;
- taps shall be provided in the high voltage winding (69 kV side), with steps of +4 and -6 at 2.5% (+10% & -15%) taps above and below the primary voltage rating (69 kV); and
- The bidder shall state in the technical schedule, the percentage regulation at full load, power factor 1.0 and at full load power factor 0.8 lagging. The primary and secondary voltage variation shall be based on a winding temperature rise of 65⁰C.

7. MOBILE TRANSFORMER COOLING

These mobile transformer type oil coolers shall be complete with copper liner tubes and aluminium extruded fins, pumps and fans. The system shall incorporate two pipe systems for the flow of the oil. The heat exchanger shall be designed to provide the maximum cooling efficiency. The cooling system can consist of two pumps and multiple fans. When one pump shuts down, the cooling system shall be capable of providing adequate cooling for continuous operation at 70% of rated transformer's capacity, indefinitely with no adverse or abnormal effect on the transformer. Pumps and fans shall not be controlled by winding temperature and must be energized at all times during normal operation.

All piping between the transformer and the heat exchanger shall be seamless metal and incorporate stainless steel flex joints to allow for vibration and expansion without any adverse effects. Pipe fittings and valves are suitable for high pressure applications.

8. MOBILE TRANSFORMER PROTECTION

The operation of the MV breaker shall be coordinated such that any short circuit and/or overloading on the secondary side of the transformer will activate the MV protective devices first, tripping the MV breaker before the HV protective devices operate, taking the load off the transformer before the core and/or coil is/are thermally and/or mechanically damaged.

The operation of the protection devices mentioned above shall be indicated externally on the cabinet, and the circuit breaker shall be made to be externally controlled.

The characteristics of the protection device shall allow for full usage of the transformer's continuous rating and short-time overload capabilities for emergency loading condition (120% of nominal kVA rating for 2 hours within a 12-hour period).

The Bidder shall submit the characteristic curves of the over-current protection device with the bid. The characteristic curve shall also include the transformers' through-fault withstand capability curves or transformer damage curves.

9. BIL RATING

The transformer shall be rated not more than 95 kV BIL for the transformer MV side (15KV) and not more than 350kV BIL for the transformer HV side (72.5kV). The value of BIL is also limited by a maximum road height allowance of 5 m.

10. IMPEDANCE

The guaranteed minimum value of impedance, measured at 65⁰C and on the nominal tap position and at the rated voltage of the transformer, shall be 10.8% for the 35 MVA mobile substation transformer.

Tolerance for transformers' impedances shall be in accordance with IEEE C57.12.00, section 9.2, for impedance larger than 2.5%.

11. LOSSES and CAPITALISATION OF LOSSES

11.1 Transformer Losses

The Bidder shall state the guaranteed losses. However, no positive tolerance is allowable on the guaranteed values. If transformers are supplied with losses exceeding the guaranteed values, the purchaser reserves the right to reject the transformer(s). The mobile transformer load losses (copper loss) shall not exceed 6% at 65⁰ C and no load losses less than 10% (core loss).

The loss capitalisation formula is as follow:

$$\text{Final Bid Price (US\$)} = \text{Initial Bid Price (US\$)} + [\text{Iron Loss (kW)} \times 25.1 (\text{\$/kW}) + \text{Copper Loss (kW)} \times 22.83 (\text{US\$/kW})]$$

12. FLUX DENSITY

The flux density at any point of the magnetic circuit, core and winding, when the transformer is connected on the centre tap and operating at normal voltage and frequency, shall be stated in the bid and shall not exceed 1.78 Tesla. The transformer must be capable of operating at 10% overvoltage at 97% of rated frequency without resulting in magnetic saturation of the transformer's core or the flux density exceeding 1.9 Tesla.

13. NOISE LEVEL

The acceptable audible sound levels for all transformers shall comply with NEMA TR1, table 0-3.

Bidders shall confirm procedure for noise level measurement according to IEEE C57.12.90 and submit audible sound levels test results with the bid document.

14. RADIO INFLUENCE VOLTAGE

Radio influence voltage of all transformers, contained herein, shall comply with NEMA TRI, section 0.03.1.

15. TAP CHANGING CHARACTERISTICS

Tap positions shall be numbered as shown in Table 3 unless an acceptable alternative number of taps is provided.

Table 3: Transformer tap positions

Taps	Step %
1	10
2	7.5
3	5
4	2.5
5	0
6	-2.5
7	-5
8	-7.5
9	-10
10	-12.5
11	-15

The operating handle shall have provision for padlocking and shall give a visual indication of the tap position without unlocking.

Each tap-changer position and the tap voltage or percentage associated with voltage shall be identifiable by reference to nameplate information. All positions of the tap changer shall be operative positions.

Tap changer handles shall be fitted with covers having gaskets, so that sealing of the transformer under normal conditions is independent of the switch shaft gland.

16. CORE AND WINDINGS

The core and winding shall be capable of withstanding mechanical shocks during transport, installation and servicing.

16.1 CORE

The core shall be manufactured from burr-free, grain-oriented laminations and shall be precisely stacked to eliminate gaps in the corner joints.

Provision to the design and construction of the transformer shall be made to prevent movement of the core and windings, relative to the tank, during transport, installation and short-circuits.

The design shall avoid the presence of pockets, which can prevent complete emptying of the oil in the tank through its drain plug.

16.2 WINDINGS

The transformer windings should be arranged such that a vector group of YNd11 is achieved.

17. BUSHINGS AND TERMINATIONS

17.1 BUSHINGS

Bushings shall be of the outdoor type and easily replaceable. The bushings shall be sufficiently robust (mechanically) to withstand normal transport and erection hazards.

All bushings shall have a minimum creepage distance of 25 mm/kV for maximum phase-to-phase system voltage, and shall have a continuous rating of 200 % of the transformer capacity rating.

Polymer bushings can be used to leverage weight savings.

Bushings should be such that they contain all necessary current transformers for measurement and protection.

17.2 BUSHING LABELS

HV bushings shall be labelled L1, L2, L3 and L4.

MV bushings shall be labelled L1 to L3 in accordance with IEEE C57.12.70 standards.

Marking letters shall be at least 80 mm (or 3 inches) high. The means of marking shall conform to the requirements of the section on Labels in this specification.

18. EARTHING TERMINALS

All transformers shall be provided with earthing/grounding terminals which shall be of non-ferrous material but not plastic.

19. TRANSFORMER OIL

The transformers shall be supplied filled with class 1 mineral oil conforming to ASTM D3487. The

complete first filling shall be of new oil free from inhibitors and additives. The dielectric strength of the oil shall not be less than 72.5kV. If an anti-oxidant inhibitor is recommended, its use shall be subject to the Purchaser's approval.

20. FITTINGS

The following standard fittings shall be provided:

- rating, diagram and terminal marking plate;
- tank grounding terminal;
- lifting lugs;
- oil level indicator;
- manual pressure relief device; and
- drain/sampling valve with plug.

The fittings and accessories listed above are only indicative and any other fittings and accessories according to the applicable standards herein shall be provided for the transformers.

21. RATING AND CONNECTION PLATE

Each transformer shall be provided with anodized aluminium laser engraved nameplate, in accordance with IEEE C57.12 - Nameplate A and C as necessary. Additionally, Proponents shall ensure that the following attributes are indicated on the aforementioned nameplate and conform to the requirements of the section on Labels in this specification:

1. standard to which it is manufactured and tested;
2. identification of internal short-circuit and overload protection devices;
3. type of cooling;
4. rated currents in A;

5. chopped wave (short time) impulse voltage withstand level in kV;
6. power frequency withstand voltage in kV;
7. percentage impedance at 65⁰C;
8. load loss in kW at rated current;
9. no-load loss in kW at rated voltage and frequency;
10. continuous ambient temperature at which ratings apply in ⁰C (40);
11. top oil and winding temperature rise at rated load in ⁰C;
12. winding connection diagram;
13. total mass (core, windings and oil) in kg;
14. mass of core and windings in kg;
15. volume of oil in litres;
16. Oil with less than 2ppm of PCB; and
17. name of the purchaser (Property of Guyana Power & Light Inc.)

22. SURFACE TREATMENT

The transformer tank and all accessories shall be treated in accordance with IEEE C57.12. 29 to ensure enclosure and equipment integrity.

23. SUPPRESSION OF HARMONICS

Each transformer's core shall be designed with attention to the suppression of harmonic voltages and currents, as per IEEE Std 519-2014 in Table 1 for bus voltage between 1 kV and 69 kV and Table 2 for current distortion limits for systems rated 120 V through 69 kV.

Proponents shall submit results for harmonic suppression tests for voltage and current distortions.

24. TESTS

In addition to the routine tests required in IEEE C57.12.00, as per section 8 and Table 18, the following additional tests shall be carried out on all transformers. The following routine measurements and tests shall be carried out and results shall be submitted to the Purchaser upon delivery:

- a) Measurement of winding resistance at the nominal and extreme tap positions for each transformer provided;
- b) Measurement of impedance;
- c) Measurement of no-load loss and no-load currents at full, 90% and 110% voltages;
- d) Induced overvoltage withstand test;
- e) Separate source voltage withstand tests on HV and MV windings;
- f) Magnetic balance test;
- g) Polarization Index Test. The index shall be not less than 1.5;
- h) Oil leakage test: The criterion of leakage shall be discolouration by oil of whitewash applied externally to suspected parts at an oil temperature of 90⁰C or other method approved by the Purchaser;
- i) Bushings and oil shall be subject to the following routine tests.
 - a. bushing routine tests
 - b. oil dielectric and moisture content test.

Routine test certificates shall include in addition to the test results, the Purchaser's order number, the transformers' serial numbers, outline drawing number and transformer kVA rating.

Upon acceptance of Tender, the Manufacturer/Proponent shall provide results of standard design type tests required in Table 18 of IEEE C57.12.00.

25. MOBILE SUBSTATION SINGLE LINE DIAGRAM

SLD of Mobile Substation

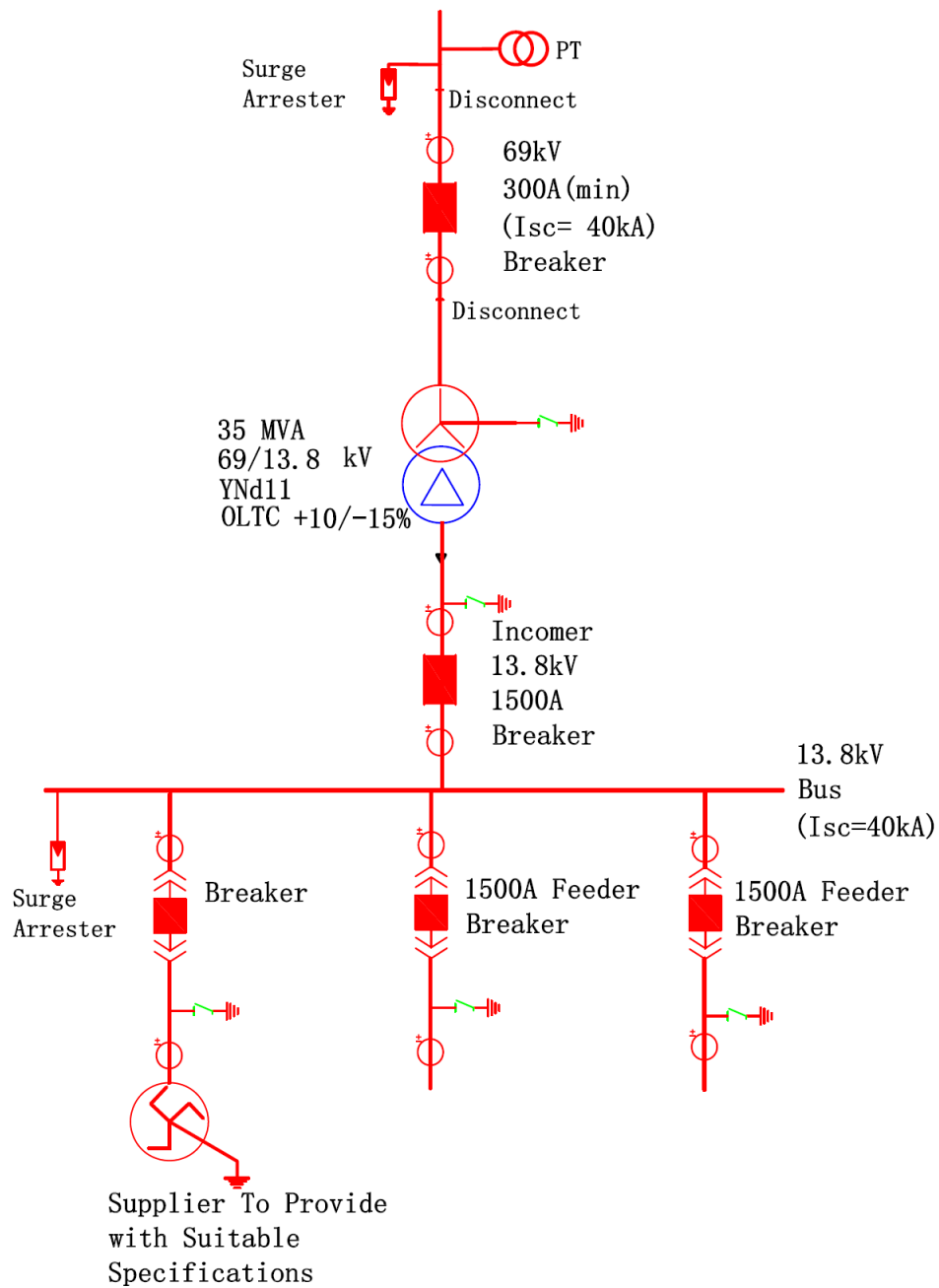

26. HV CONNECTION

The Mobile substation shall be designed to connect to existing HV electrical infrastructure using overhead lines.

27. AUXILIARY SYSTEMS

All auxiliary systems including AC and DC power supply, communication, and other necessary support systems to allow a fully functional mobile substation shall be included.

28. HV SWITCHGEAR

The use of rack out mechanisms are permitted for use on the HV side equipment. Assembly for energization should be easy and not requiring any lifting devices. The mechanisms must be strong enough to withstand transportation stresses, switching forces, short circuit forces, loss of conductor and seismic forces (such as earthquakes of up magnitude 5.0 on the Richter scale).

The HV Switchgear could be of the hybrid type or GIS type. The circuit breaker shall be adequately rated and equipped to facilitate measurement and protection.

The measurement and protection current transformers shall be within the circuit breaker bushings and shall have a secondary current of 5A.

The HV switchgear shall consist of a circuit breaker and two disconnect switches and earthing switch which are capable of remote operation and indication via the SCADA system.

The control voltage shall be 125VDC.

29. MV SWITCHGEAR

The MV Switchgear should be either GIS or Vacuum type. The switchgear shall consist of two feeder circuit breakers, one circuit breaker to accommodate an appropriately sized Zig-Zag grounding transformer (to be supplied also) with earthing switches and cubicles and one incomer circuit breaker. All MV circuit breakers shall be capable of remote operation and indication (including indication of earthing switches' position) from SCADA.

The measurement and protection current transformers shall be within the circuit breaker cubicles and shall have a secondary current of 5A.

The control voltage shall be 125VDC.

30. SURGE ARRESTORS

The lightning arrestors are governed by ANSI C62.11. They shall be capable of discharging lightning and switching surges and temporary power frequency over voltages, and shall be capable of discharging over voltages occurring during switching of unloaded transformers and long lines.

Surge arresters shall be installed as per Single Line Diagram (SLD) provided.

The Arrestors (both HV and MV) shall be capable of withstanding Maximum Continuous Operating Voltages (M.C.O.V) and rated for operation in 72.5 kV and 15 kV class systems. The reference current of the arrestors shall be of such value to eliminate the influence of grading and stray capacitance on the measured reference voltages.

These arrestors shall be of Heavy Duty, Zinc Oxide type and shall be hermetically sealed units suitable for outdoor installation. Additionally, the arrestors shall be suitable for heavily polluted atmospheric conditions as mentioned in section 3 on page 21.

31. TRAILER DESIGN

The trailer shall not exceed 3.5 m wide or 5 m high. The total length of the trailer shall not exceed 15.5 m. The use of multiple axles with hydraulic steering or even the use of a dolly to assist in weight distribution is permitted. The maximum permissible weight per axle should not exceed 14 Tons. The kingpin capacity should be adequate to withstand at least 1.5 times the total applied loading by the substation. In addition, the power attachments shall be suitable to work with standard mechanisms for appropriate towing trucks.

32. CONTROL, PROTECTION, METERING AND SCADA

The control, metering and relay protection panels shall be in a suitable temperature-controlled enclosure with easy access and adequate space for one operator. Ease of maintenance must also be considered.

All control, metering and protection relays shall be IEC61850 compliant and be easily integrated into a SCADA system.

Metering shall be done at both the HV and MV side of the transformer either by separate devices or via the numerical protection relays.

The minimum required electrical and non-electrical protection relay function for the transformer and other parts of the mobile substation shall include, but not limited to the following:

1. Phase transformer differential (87P);
2. Unrestrained differential (87U);
3. Negative sequence differential (87Q);
4. Ground differential (87N);
5. ground differential (87) protection;
6. thermal overload (49W);
7. over-fluxing protection relay (24);
8. Under (27) and Over (59) Voltage on both sides;
9. Negative Sequence (47);
10. Phase over current on both sides (50,51) – with directional capability;
11. Ground over current on both sides (50 G/N, 51 G/N) – with directional capability;
12. Sudden Pressure (63);
13. Lockout auxiliary (86);
14. Oil level switch (71Q);
15. Apparatus thermal device (26Q);
16. Buchholz Relay (for conservator);
17. Gas accumulator (33);
18. Over (81O) and Under (81U) frequency for MV side; and
19. All auxiliaries of the mobile substation, which includes pumps etc. shall also be equipped with all relevant relay protected functions.

33. CABLE REEL

The trailer shall accommodate one or two MV cable reels with three sections to accommodate six (6) pieces of cables (333ft each) on the reel with combined total length of 2000ft – Single (1) core (500mmsqr) Armored Cable, 15kV Class, XLPE power Cable, Compact Copper Conductor, 133% Insulation, Copper tape shield with PVC Sunlight Resistant Jacket. Termination kits and lugs to match the supplied feeder cubicle connections are to be provided as well.

34. COMPLIANCE WITH SPECIFICATION

The transformers shall comply in all respects with the requirements of this specification. However, any minor departure from the provisions of the specification shall be disclosed at the time of tendering in the Non-Compliance Schedule in this document (see page 41).

35. COMPLIANCE WITH REGULATIONS

All the transformers/equipment shall comply in all respects with the Laws of Guyana Governing the Importation of Commercial Items and/or Goods.

The equipment and connections shall be designed and arranged to minimize the risk of fire and any damage that might be caused in the event of a fire.

36. QUALITY ASSURANCE, INSPECTION AND TESTING

36.1 GENERAL

To ensure that the supply and services are in accordance with the Specification herein, with the regulations of Guyana and with relevant authorized international standards, the Proponent shall have in place suitable Quality Assurance Programmes and Procedures to ensure that all activities are being controlled and documented as necessary.

The quality assurance arrangements shall conform to the relevant requirements of ISO 9001 or ISO 9002, as deemed appropriate by the Purchaser and the Proponent.

The systems and procedures that the Proponent will use to ensure that the supply complies with the specified requirements, shall be defined in the Proponent's Quality Plan.

The Proponent shall operate systems that implement the following:

Hold Point "A stage in the material procurement or workmanship process beyond which work shall not proceed without the documented approval of designated individuals or organisations."

The Purchaser's written approval is required to authorise work to progress beyond the Hold Points

indicated in approved Quality Plans.

Notification Point “A stage in material procurement or workmanship process for which advance notice of the activity is required to facilitate witness.”

If the Purchaser's representative does not attend after receiving documented notification in accordance with the agreed procedures and with the correct period of notice then work may proceed.

36.2 QUALITY ASSURANCE SYSTEM

Unless the Proponent's Quality Assurance System has been audited and approved by the Purchaser, a Quality Assurance System shall be submitted to the Purchaser for approval within a minimum of One (1) month from the placement of order, or such other period as shall be agreed with the Purchaser. The Quality Assurance System shall provide a description of the Quality Control System for the supply and shall, unless advised otherwise, shall include, but not limited to the following details:

1. The structure of the organisation;
2. The duties and responsibilities assigned to staff to ensure quality of work;
3. The system for purchasing, taking delivery and verification of the specifications of raw materials;
4. The system for ensuring the quality of workmanship
5. The system for control of documentation;
6. The system for the retention of records; and
7. The arrangement for the Proponent's internal auditing.

36.3 QUALITY PLANS

The Quality Plans shall set out the activities in a logical sequence and, unless advised otherwise, shall include, but limited to the following:

1. An outline of the proposed programme sequence;
2. The duties and responsibilities assigned to staff ensuring the quality of work;

3. Hold and notification points;
4. Submission of engineering documents required by the specification;
5. The inspection of materials and components on receipt;
6. Reference to the Supplier's procedures appropriate to each activity;
7. Inspection during fabrication and assembly; and
8. Final inspection and test.

36.4 INSPECTION AND TESTING

The Purchaser shall have free entry at all times, while work on the order is being performed, to all parts of the manufacturer's working area which are in relation to the processing of the mobile substation ordered.

The Manufacturer/Proponent shall afford the Purchaser without charge, all reasonable facilities to assure that the mobile substation being furnished are in accordance with the specifications herein.

The equipment shall have successfully passed all tests as described in Section 24 (see page 29).

The Purchaser reserves the right to reject an item of the mobile substation if the test results do not comply with the values specified herein.

Tests, including any retests required, shall be carried out by the Supplier at no extra charge, at the manufacturer's works.

Full details of the proposed methods of testing, including connection diagrams, shall be submitted to the Purchaser by the Supplier for approval, at least one month before testing.

All costs in connection with the testing, including any necessary re-testing, shall be borne by the Manufacturer/Proponent.

Any cost incurred by the Purchaser in connection with inspection and re-testing as a result of the failure of the mobile substation or any of its components under test or damage during transport or offloading shall be to the account of the Proponent.

The Proponent shall submit to the Purchaser three signed copies of the test certificates, giving the results

of the tests as required. No materials shall be dispatched until the test certificates have been received by the Purchaser and the Proponent has been informed that they are acceptable.

The test certificates must show the actual values obtained from the tests, in the units used in this specification, and **not** merely confirm that the requirements have been met.

No inspection or lack of inspection or approval by the Purchaser's Representative of equipment or materials whether supplied by the Proponent or a Sub-Proponent, shall relieve the Proponent from his/her liability to complete the contracted works in accordance with the contract would exonerate him/her from any of his/her guarantees.

36.5 GUARANTEE

The Proponent shall guarantee the following:

- Quality and strength of materials used;
- Satisfactory operation during the guarantee period of one (1) year from the date of commissioning, or 18 months from the date of acceptance of the equipment by the Purchaser following delivery, whichever is the earlier. The Purchaser shall advise the Proponent of the date of commissioning;
- Performance figures as supplied by the Proponent in the Technical Data Schedule, the guaranteed copper and iron losses and other particulars;
- The offered surface treatment shall protect the treated metal from corrosion for a period of not less than ten (10) years from the date of delivery.

37. SPARE PARTS AND SPECIAL TOOLS

The Proponent shall provide a list of recommended spare parts and their individual prices and shall include HV and MV bushings. This list shall identify all essential spares and consumable items for any recommended maintenance for a period of five (5) years after commissioning.

The Purchaser may order all or any of the spares parts listed at the time of placement of order.

A spare parts catalogue with price list shall be provided and this shall form part of the drawings and literature to be supplied with the bid.

The Proponent shall give an assurance that spare parts and consumables will continue to be available through the life span of the equipment/transformers, which shall be 25 years minimum. However, the Proponent shall give a minimum of 12 months' notice to the Purchaser, in the event that the Proponent or any Sub-supplier, plan to discontinue manufacturing of any component used in the transformers.

Any spare apparatus, parts or tools shall be subjected to the same specification herein, tests and conditions as similar main material supplied. They shall be strictly interchangeable and suitable for use in place of the corresponding parts supplied with the mobile substation and must be suitably marked and numbered for identification.

Spare parts shall be delivered suitably packaged and treated for long periods in storage. Each package shall be clearly and indelibly marked with its contents, including a designation number corresponding to the spare parts lists in the operation and maintenance instructions.

38. LABELS

All apparatus shall be clearly labelled indicating, where necessary, its purpose and service positions.

The material of all labels and plates, their dimensions, legend and the method of printing shall be subject to the approval of the Purchaser.

Colours shall be permanent and free from fading. All labels and plates for outdoor use shall be of non-corrosive material.

They shall be engraved in English. Nameplates shall carry all the applicable information specified in the applicable items of the Standards and other details as required in this specification. No scratching, corrections or changes will be allowed on nameplates.

Wherever possible the equipment shall carry the markings "**THIS EQUIPMENT IS PROPERTY OF GPL Inc.**".

39. DECALS

“Danger do not open” decal on exterior transformer doors

“Danger do not touch” decal on interior transformer doors

Typical decals shown in Appendix A.

40. SUBMITTALS REQUIRED WITH THE BID

The following shall be required in duplicate of three (3) copies:

1. completed technical data schedule for the mobile substation;
2. descriptive literature giving full technical details of equipment offered;
3. Outline dimension drawings for each major component, general arrangement drawing showing component layout and general schematic diagrams;
4. type test certificates, where available, and sample routine test reports for the mobile substation;
5. summary reference list of customers already using equipment offered during the last 5 years with particular emphasis on units of similar design and rating;
6. details of manufacturer's quality assurance standards and programme and ISO 9000 series or equivalent national certification;
7. deviations from this specification. Only deviations approved in writing before placement of order shall be accepted; and
8. list of recommended spare parts and consumable items for five years of operation with prices and spare parts catalogue with price list for future requirements.

41. NON-COMPLIANCE SCHEDULE

On this schedule, the Proponent shall provide a list of non-compliance with this specification, documenting the effects that such non-compliance is likely to have on the transformer/equipment/component life span and operating characteristics. Each non-compliance shall be referred to the relevant specification clause.

Clause No.	Non-Compliance

42. TEST CERTIFICATE SCHEDULE

On this schedule, a list of the test certificates shall be included with the bid. This list shall include the certificates for the type tests and sample routine test reports. Each certificate listed shall be referred to the relevant specification clause.

Clause No.	Type Test Certificate or Routine Test Report

43. SHIPPING

The Manufacturer/Proponent shall prepare the transformers and other equipment for shipping in such a manner as to protect from them from damage or deterioration during shipping and storage, and shall be responsible for, and make good, any and all damage due to improper preparation for loading, shipment and storage.

44. TECHNICAL SCHEDULE

Description	Unit	Data
Rated Power	kVA	
Rated Frequency	Hz	
Rated Primary Voltage	kV	
Rated Secondary Voltage	V	
No. of Tap Positions/Steps	No.	
Max Tap Position	%	
Min Tap Position	%	
Magnetic Flux Density	Tesla	
No Load Current	A	
No-load Loss at Nominal Tap Position and Rated Primary Voltage	kW	
Load Loss at Nominal Tap Position and Rated Load Current	kW	
Voltage Regulation at Full Load and Power Factor of 1	%	
Voltage Regulation at Full Load and Power Factor of 65% winding temperature rise	%	
Rated Short-circuit Current	kA	
Rated Short-circuit Current withstand duration	s	
Impedance measured at 65 °C and nominal tap position	%	
X/R Ratio	%	
Overloading		
Duration of 25% Overload	minutes	
Duration of 50% Overload	minutes	
Temperature Rise		
Design maximum outdoor temperature	°C	
Design continuous ambient temperature	°C	
Average Winding Temperature Rise	°C	
Maximum Winding Temperature Rise	°C	
Maximum Hot Spot Temperature Rise	°C	
Hot Spot to Top oil Temperature Gradient	°C	
General Transformer Data		
Manufacturer	...	
Type and Grade	...	
Operating flux density	Tesla	
Losses kW/kg at operating flux density	kW/kg	
Manufacturer's data sheet supplied	YES/NO	
Windings/Coils		

Conductor for HV Winding - Manufacturer/Supplier and Type		
Conductor Material for HV Winding		
Conductor for MV Winding - Manufacturer/Supplier and Type		
Conductor Material for MV Winding		
Bushings & Terminals		
HV Bushing Manufacturer/Supplier		
HV Busing Type and Grade		
HV Bushing Catalogue Number		
MV Bushing Manufacturer/Supplier		
HV Bushing BIL	kV	
HV Busing Power Frequency withstand Voltage	kV	
Type and Mental used in HV Terminal		
MV Busing Type and Grade		
MV Bushing Catalogue Number		
MV Busing Power Frequency withstand Voltage	kV	
Type and Mental used in MV Terminal		
Type and Mental used in Earth Terminal		
Bushing Clearance		
Minimum phase to phase clearance	mm	
Minimum earth to phase clearance	mm	
Spring and lock washer included	YES/NO	
Tap Changer		
Tap Changer Manufacturer/Supplier		
Tap Changer Type		
Tap Changer Catalogue Details Attached	YES/NO	
Can the Tap Changer switch be Locked	YES/NO	
Tank		
Tank material		
Thickness of the metal sheet		
Painting method details attached	YES/NO	
Tank Width	mm	
Tank Height	mm	
Tank Dept	mm	
Weight of Core and Windings	kg	
Weight of Tank	kg	
Weight of Oil at 20 °C	kg	
Total weight of Transformer without oil	kg	
Shipping weight of Transformer	kg	
MV Switchgear		
Manufacturer		
Type of switchgear		

Voltage rating	kV	
Current rating	A	
Current transformer ratings	A	
Short circuit withstand capability	kA	
Control voltage	V	
Catalogue number		
Main construction material		
Painting method details attached		
Weight of assembled switchgear	Kg	
Manufacturer's datasheet attached	Yes/No	
HV Switchgear		
Manufacturer		
Type of switchgear		
Voltage rating	kV	
Current rating	A	
Current transformer ratings	A	
Short circuit withstand capability	kA	
Control voltage	V	
Catalogue number		
Main construction material		
Painting method details attached		
Weight of assembled switchgear	Kg	
Manufacturer's datasheet attached	Yes/No	
Trailer		
Manufacturer		
Manufacturer's datasheet attached		
Trailer dimensions	W*L*H	
Trailer weight	Kg	
Number of steerable axels		
Number of non-steerable axels		
Weight Capacity of trailer	Kg	

Affix Company Seal Below

Name:.....

Signature:.....

Date:.....

Technical Specifications for 16.7, 20 & 35MVA ONAN Rated Three Phase Power Transformers

1. SCOPE

This specification covers the design, manufacture, shop testing, pre-delivery inspection, packing at manufacturer's works, transit insurance, delivery to GPL as per request of 16.7 MVA, 20 MVA and 35 MVA, ONAN rated, 69kV/13.8kV, copper wound, power transformers, complete with all accessories/fittings with first filling of new transformer oil in vacuum conditions and 10% extra transformer oil as specified herein and suitable for outdoor installation.

2. APPLICABLE STANDARDS

Except where modified by this specification, the transformer shall be designed, manufactured and tested in accordance with the latest edition(s) of the standards shown in Table 1. The Proponent may propose alternative standards, but shall demonstrate that the alternatives give a degree of quality and performance equivalent to or better than the referenced standards herein.

Acceptability of an alternative standard is at the discretion of the Purchaser.

The Proponent shall furnish a copy of the alternative standard(s) along with the bid. If the alternative standard is not written in the English Language, a certified English Language translated version of the original standard shall be submitted with the bid.

Table 4: Applicable Standards

Item No.	ANSI/IEC/IEEE/ISO Standards	Title
1	IEEE C57.12.00	Standard for General Requirements for Liquid-Immersed Distribution, Power, and Regulating Transformers
2	ANSI/IEEE C57.106	Guide for Acceptance and Maintenance of Insulating Oil in Equipment

Item No.	ANSI/IEC/IEEE/ISO Standards	Title
3	ANSI/IEEE C57.92	Guide for Loading Mineral-Oil-Immersed Power Transformers up to and Including 100 MVA with 55 Degrees C or 65 Degrees C Average Winding Rise
4	NEMA TR1	Transformers, Regulators and Reactors
5	IEC 60076	Power transformers
6	IEEE C57.12.90	Standard Test Code for Liquid-Immersed Distribution, Power, and Regulating Transformers Corrigendum 1:Editorial and Technical Corrections
7	ANSI C57.12.20	Overhead-Type Distribution Transformers 500 kVA and Smaller; High Voltage, 34 500 V and Below; Low Voltage, 7970/13 800Y V and Below
8	IEEE Std 519	Recommended Practice and Requirements for Harmonic Control in Electric Power Systems
9	IEC 600137	Insulated bushings for alternating voltages above 1 000 V
10	IEEE C57.12.70	Standard for Standard Terminal Markings and Connections for Distribution and Power Transformers
11	IEEE C57.156	Guide for Tank Rupture Mitigation of Liquid-Immersed Power Transformers and Reactors
12	IEEE C57.12.31	Standard for Pole-Mounted Equipment-Enclosure Integrity
13	IEC 61099	Insulating liquids - Specifications for unused synthetic organic esters for electrical purposes
14	IEC 60836	Specifications for unused silicone insulating liquids for electrotechnical purposes

Item No.	ANSI/IEC/IEEE/ISO Standards	Title
15	IEC 62535	Insulating liquids - Test method for detection of potentially corrosive sulphur in used and unused insulating oil
16	IEEE C57.12.91	Standard Test Code for Dry-Type Distribution and Power Transformers
17	ISO 9001	Quality management systems - Requirements
18	ISO 9002	Quality management systems. Guidelines for the application of ISO 9001:2015
19	ISO 9000	Quality Management Systems - Fundamentals and Vocabulary

In case of conflict(s) with applicable standard(s), the order of precedence shall be:

- This Technical Specification for Power Transformer; then
- Other Applicable and Recognised Standards for Power Transformers.

3. INSTALLATION/SERVICE CONDITIONS

The installation conditions of the transformer shall be as follows:

6. Maximum altitude above mean sea level less than 1,000 m above sea-level
7. Maximum ambient air temperature 40⁰C
8. Maximum daily average ambient air temperature 35⁰C
9. Minimum ambient temperature 15⁰C
10. Maximum relative humidity 100%
11. Wind Speed at typical transformer height 3 m/s
12. Isokeranic level 120
13. Average Number of days with rain 206 days per year (> than 0.1 mm)

14. Average annual rainfall

188.4 mm

All outdoor materials, components and equipment shall be designed and protected for use in exposed, heavily polluted and salty, corrosive and humid tropical coastal atmospheric conditions.

Maximum temperature rise over ambient temperature:	
• In oil by thermometer	65 °C
• In winding by resistance measurement	65 °C
• Limit for hot spot temperature for which the transformer is designed	<80 °C
• Temperature gradient between windings and oil	20 °C
• Type and details of winding hot spot temperature detector	Resistance temperature detector
• Type of maximum winding temperature indicator	analog/ digital
Average Winding Temperature Rise	65 °C
Maximum Winding Temperature Rise	105 °C

4. ELECTRICAL SYSTEM CONDITIONS

The transformer shall be suitable for installation as a Generator Step-up Unit (GSU) or as a Substation Step-down Power transformer within GPL’s Power System, which has the following characteristics (see Table 2).

Table 5: Characteristics of GPL’s Power System

Nominal System Voltage, Frequency and Phase	High Voltage (HV) Side	69 kV, 60 Hz, 3φ-3-wire, Wye
	Medium Voltage (MV) Side	13.8 kV, 60 Hz, 3φ-3 wire, Delta
Voltage Class – High Voltage Side	75 kV	
Voltage Class – Medium Voltage Side	15 kV	
Short circuit withstand Capability	As per IEEE C57.12.00, section 7.1.4	

Insulation Level		
Basic Insulation Level (BIL)	110 kV for 13.8 kV side (Medium Voltage Level)	
	350 kV for 69 kV side (High Voltage Level)	
Power Frequency withstand level – Dry 1 Minute	36 kV for 13.8 kV side (Medium Voltage Level)	
	160 kV for 69 kV side (High Voltage Level)	
Power Frequency withstand level – Wet 10 Seconds	30 kV for 13.8 kV side (Medium Voltage Level)	
	140 kV for 69 kV side (High Voltage Level)	
Creepage Distance (minimum)	25 mm/kV for line-to-line and 44 mm/kV for line-to-ground for both 69 kV side (High Voltage Level) and 13.8 kV side (Medium Voltage Level).	
System Grounding		
Neutral Grounding	High Voltage Side	Wye - Solidly Grounded.
	Medium Voltage Side	13.8 kV busses are grounded via a zig-zag transformer with a resistor in neutral connection to earth.

5. AUXILIARY POWER SUPPLIES

The following power supplies shall be available at site:

- AC 3-phase, 480 volts, 60Hz, Earthed;
- AC 1-phase, 240/120 volts, 60Hz. Earthed; and
- 125 volts DC for essential alarms, indication and circuit breaker tripping.

6. TYPE OF TRANSFORMER

The transformer shall be double wound, sealed type, oil immersed with natural oil cooling (ONAN), three phase (3 ϕ) with ratings as specified herein. Additionally, the power transformer shall be completed with all accessories/fittings/ancillaries with first filling of new transformer oil in vacuum condition(s) and 10% extra transformer oil as specified herein and suitable for outdoor installation, all as per ANSI/IEEE C57.106.

The vector ground of the transformer shall confirm to YNd11 and is required to be equipped with four (4) HV and three (3) MV bushing terminations.

The design of the tank, fittings, bushings, etc., shall be of such that it will not be necessary to keep the transformer energised to prevent deterioration as the transformer may be held in reserve and outdoors conditions for many years.

7. RATINGS

The rating of the power transformer shall be 16.7 MVA, 20MVA and 35 MVA, all units at ONAN rating.

The transformer, inclusive of tap changer and other load current carrying components, shall accept emergency overloading as per ANSI/IEEE C57.92, section 4.

8. TAPS AND VOLTAGE REGULATION

The transformer shall have the following voltage transformation ratio and tapping range:

- the nominal high-side voltage for the transformer shall be 69 kV and the medium-side voltage shall be 13.8 kV and conform to the vector group YNd11.
- tolerance on the voltage ratio shall be in accordance with IEEE C57.12.00, section 9.1;
- taps shall be provided in the high voltage winding (69 kV side), with steps of 1.25%, where there shall be four (4) steps above and eight (8) steps below the nominal primary voltage rating of 69 kV; and
- bidder shall state in the technical schedule, the percentage voltage regulation at full load, at power factor of 1.0 and at full load at power factor of 0.8 lagging. The primary and secondary voltage variation shall be based on a winding temperature rise of 65⁰C.

9. IMPEDANCE

The guaranteed value of impedance, measured at 65⁰C and on the nominal tap position and at the rated voltage of the transformer, shall be 11.48% for the 16.7 MVA transformer and 11.29% for the 20, and 10.9 % for the 35 MVA.

Tolerance for transformers' impedances shall be in accordance with IEEE C57.12.00, section 9.2, for impedance larger than 2.5%.

It should be noted that multiple similarly rated transformers should be capable of operating in parallel and having the above impedances. The transformer should not exceed a footprint of 8000mm X 5300mm.

10. SHORT CIRCUIT RATINGS

Bidders must submit all short circuit test results for compliance with IEEE C57.12.00, section 7.1.4.

11. LOSSES and CAPITALISATION OF LOSSES

The acceptable range for iron (or core) and copper (or load) losses of the transformer is as follow:

- A. Iron loss in function of nameplate rating of transformers: 0.08% to 0.1%;
- B. Copper loss in function to nameplate rating of transformers at full load: 0.38% to 0.48%; and
- C. The acceptable total transformer losses at full load: 0.47% to 0.6% of nameplate rating.

Bidders shall guarantee that each loss component, as mentioned above, should not exceed by 10% for individual loss component and 15 % for the total transformer losses at full load.

The losses proposed by the Bidders shall be measured during routine tests. If the results from the routine tests indicate that either the copper or iron loss is more significant than the Bidder's guaranteed values, the Purchaser shall have the right to reject the transformer(s).

The capitalization of guaranteed losses of the transformer shall be calculated and considered while evaluating the bids as the final bid price. The guaranteed values of no-load losses and load losses shall be stated in the bid, which should match the corresponding loss figures mentioned in the short circuit type test report submitted along with the offer by the bidder. Liquidated damages will be applied to successful bidder for not achieving the quoted guaranteed figures.

The loss capitalisation formula is as follow:

For 35 MVA Transformer:

$$\text{Final Bid Price (US\$)} = \text{Initial Bid Price (US\$)} + [\text{Iron Loss (kW)} \times 12.47 (\text{\$/kW}) + \text{Copper Loss (kW)} \times 6.37 (\text{US\$/kW})]$$

For 20 MVA Transformer:

$$\text{Final Bid Price (US\$)} = \text{Initial Bid Price (US\$)} + [\text{Iron Loss (kW)} \times 12.47 (\text{\$/kW}) + \text{Copper Loss (kW)} \times 6.77 (\text{US\$/kW})]$$

For 16.7 MVA Transformer:

$$\text{Final Bid Price (US\$)} = \text{Initial Bid Price (US\$)} + [\text{Iron Loss (kW)} \times 12.74 (\text{\$/kW}) + \text{Copper Loss (kW)} \times 8.27 (\text{US\$/kW})]$$

12. FLUX DENSITY

The flux density at any point of the magnetic circuit, core, and winding, when the transformer is connected on the centre tap and operating at normal voltage (from either sides) and frequency, shall be stated in the bid and shall not exceed 1.15 Tesla (operating flux density). The transformer must be capable of operating at 20% overvoltage at 95% of rated frequency without resulting in magnetic saturation of the transformer's core or the flux density exceeding 1.5 Tesla.

The transformer shall be designed to have an operating overvoltage capability of 112.5% of rated voltage (continuous).

13. NOISE LEVEL

The acceptable audible sound levels for all transformers shall comply with NEMA TR1, Table 0-3.

Bidders shall confirm procedure for noise level measurement according to IEC 60076-10 or IEEE C57.12.90 and submit audible sound levels test results with the bid document.

14. RADIO INFLUENCE VOLTAGE

Radio influence voltage of all transformers, contained herein, shall comply with NEMA TRI, section 0.03.1.

15. TAP CHANGING CHARACTERISTICS

Tap positions shall be numbered as shown in Table 3 and in accordance with ANSI C57.12.20, section 6.2.1, and shall be designed to operate as an automatic on-load tap changer. The design shall also provide for manual override of the automatic on-load tap changer in the event of an emergency.

A remote controller for the on-load tap changer is required and will be placed 80m to 100m away from the

transformer. The means of signal transmission (electrical or optical) should be stated in the bid submission. At minimum, the unit must display the mode of operation, the current tap position, indication of action (up or down) and time elapsed during change action. The unit shall be IEC 61850 compliant to connect to SCADA system using protocol 101, must have clearly marked operation buttons and work with a power supply of 125VDC.

Table 6: Transformer onload tap positions.

Tap Position	HV Side Voltage (kV)
Tap 1	72,450
Tap 2	71,590
Tap 3	70,725
Tap 4	69,865
Tap 5	69,000
Tap 6	68,140
Tap 7	67,275
Tap 8	66,415
Tap 9	65,550
Tap 10	64,690
Tap 11	63,825
Tap 12	62,965
Tap 13	62,100

Each tap-changer position and tap voltage or percentage associated with nominal voltage shall be identifiable by reference to nameplate information. All positions of the tap changer shall be operative positions.

Tap changer handles shall be fitted with covers having gaskets, so that sealing of the transformer under normal conditions is independent of the switch shaft gland.

16. CORE AND WINDINGS

The core and windings shall be vacuum processed to ensure maximum penetration of insulating fluid into the coil insulation system. While under vacuum, the windings will be energized to heat the coils and drive out moisture, and the transformer shall be filled with preheated filtered degassed insulating fluid.

The core and winding shall be capable of withstanding mechanical shocks during transport, installation,

and servicing, inclusive of thermal and mechanical stresses caused by any symmetrical and asymmetrical faults on any winding.

The transformer shall be provided with winding temperature indicator and combined alarm and trip relays of approved design, oil temperature indicator of approved design incorporating contacts and relay(s) for initiating alarms and trips, Buchholtz relay and low oil level alarm.

a. CORE

The core shall be manufactured from burr-free, grain-oriented silicon steel laminations and shall be precisely stacked to eliminate gaps in the corner joints.

Provision to the design and construction of the transformer shall be made to prevent movement of the core and windings, relative to the tank and any other ancillary device(s) within the tank, during transport, installation and short-circuits (symmetrical and asymmetrical).

The design of the core shall avoid the presence of pockets, which can prevent complete emptying of the oil in the tank through its drain plug/pipe.

The transformer core assembly shall be boltless type.

b. WINDINGS

The winding conductor shall be of electrolytic copper, to give the optimum economic and technical results of the transformers over its operation lifespan.

The windings shall be insulated with B-stage, epoxy coated, diamond pattern, insulating paper, which shall be thermally cured under pressure to ensure proper bonding of conductor and paper, and shall be free from any other insulating compounds that are liable to soften, ooze out, shrink or collapse, and non-catalytic and chemically inert in the transformer oil during normal servicing. The windings shall be uniformly insulated, and the neutral point(s) shall be insulated for full line-to-line voltage on both sides of the transformer.

The stacks of windings shall receive adequate shrinkage treatment, and the windings and connections are to be braced to withstand mechanical shocks during transport, switching, short-circuit or other transient conditions.

The transformer shall be equipped with a buried delta winding.

17. SUPPRESSION OF HARMONICS

The transformer's core shall be designed with attention to the suppression of harmonic voltages and currents, as per IEEE Std 519-2014 in Table 1 and Table 2 for current distortion limits.

Bidders shall submit results for harmonic suppression tests for voltage and current distortions.

18. BUSHINGS AND TERMINATIONS

a. Bushings

Bushings shall be of the outdoor type and easily replaceable. Cemented types will **not** be acceptable. The bushings shall be sufficiently robust (mechanically) to withstand normal transport and erection hazards, as well as mechanical force developed for the short-circuit withstand capability current (Table 2).

All bushings shall have a minimum creepage distance of 25 mm/kV for maximum phase-to-phase system voltage and shall have a continuous rating of 200 % of the transformer capacity nameplate rating.

Bushings shall comply with IEC 600137 except where amended this specification. HV bushings shall be mounted on top of the tank, while the MV bushings shall be side wall mounted with full height air terminal. Both HV and MV bushings shall be provided with current transformers for overcurrent and differential protection, and measurement purposes of the transformer.

b. Bushing Labels

HV bushings shall be labelled H₁, H₂, H₃, H₀.

MV bushings shall be labelled X₁ to X₃ in accordance with IEEE C57.12.70 standards.

Marking letters shall be at least 12 mm (or 1/2 inch) high. The means of marking shall conform to the requirements of the section on Labels in this specification (see page 39 for further details).

c. EARTHING TERMINALS

The transformer shall be provided with at least two earthing/grounding terminals comprising an isometric bolt and nut, which shall be non-ferrous material. It shall include a spring washer and a lock washer.

External connecting strip(s) between earthing/grounding terminal and neutral bushing(s) **is/are** required.

19. TANK FABRICATION

a. GENERAL CONSTRUCTION FEATURES

All material used shall be of the highest quality and of the class most suitable for working under the conditions specified and withstand the variations of temperature and atmospheric conditions without distortion or deterioration or the setting up of undue stresses which may impair suitability of the various parts for the work which they have to perform.

Similar parts, particularly removable ones, shall be interchangeable.

Pipes and pipe fittings, screws, studs, nuts, and bolts used for external connections shall be as per the relevant standards for power transformers. Steel bolts and nuts exposed to atmosphere shall be galvanized.

Nuts, bolts, and pins used inside the transformers and tap changer compartments shall be provided with lock washer or locknuts.

Exposed parts shall not have pockets where water can be collected settled.

Internal design of transformer shall ensure that air is not trapped in any location.

Material in contact with oil shall be such as not to contribute to the formation of acid in oil. Surface in contact with oil shall not be galvanized or cadmium plated.

Labels, indelibly marked, shall be provided for all identifiable accessories like Relays, switches current transformers etc. All label plates shall be of in corrodible material.

All internal connections and fastenings shall be capable of operating under overloads and over-excitation, allowed as per specified stands without injury.

Transformer and accessories shall be designed to facilitate proper operation, inspection, maintenance, and repairs.

No patching, plugging, shimming or other such means of overcoming defects, discrepancies or errors will be accepted.

Schematic Drawing of the wiring, including external cables shall be included on the inside door of the transformer marshalling box and placed in a secured and safe position from the elements.

The tank shall be of sealed construction and fabricated using materials to withstand a minimum of 15 psi internal pressures and to mitigate rupture as per IEEE C57.156 The Proponent shall state if other than bolted cover construction is used and shall give full details of such construction.

The interior of the tank shall be sealed to avoid moisture from getting inside the parts and loss of internal pressure.

The Proponent shall state the top oil temperature that corresponds to the tank's internal pressure of 15 psi and steady load at rated capacity and emergency loading condition while considering an ambient condition stated in section 3 on page 21.

Adequate space shall be provided at the bottom of the tank for collection and draining of sediments.

Transformer tanks shall be designed to allow the unit to be lifted and transported with the total weight of the transformer, oil at the required level and any other attached ancillary, without any deformation or oil leakages. Lifting provisions shall consist lifting brackets welded to opposite sides of the tank and cover for separate lifting.

Additionally, for a total mass, equal to or greater than 2,000 kg, jacking pads shall be incorporated into the transformer tank design and construction, capable of withstanding the point load of the total mass of the transformer (tank, core, windings, and oil filled to the required level and all other attached ancillaries).

The tank shall be fabricated of construction steel with a minimum thickness of 11 mm; top and bottom covers of the tank shall have a minimum thickness of 11 mm, while the design shall ensure that skin effect is kept minimum.

Thickness below this value will be considered only in exceptional cases with a written guarantee and/or warranty from the Proponent and must be submitted along with the bid.

The transformer tank and the top cover shall be designed to conform with IEEE C57.12.31.

All sealing washers/gaskets shall be made of oil and heat resistant nitrile rubber or neoprene bonded cork seals suitable for temperatures as stipulated in this specification (see section 3 on page 21). Surfaces,

where joints have gaskets, shall be of, such that, an even surface is presented to the gasket, thereby eliminating the necessity for the gasket to take up surface irregularities.

A conservator that prevents contact between the oil in the transformer tank and the ambient air shall be provided with the transformer, e.g., either the membrane type or multi-compartment type of split conservator.

The transformers shall be equipped with a Buchholz relay complete with alarm and trip contacts, an air relief valve, flanges, and valves to enable its removal without the need to drain the oil.

Facilities should be provided for measuring the top oil temperature by the installation of a tubular pocket at the top of the tank.

The diverter switch oil compartment shall be connected to a separate conservator or segregated section of the main conservator of the transformer.

The diverter switch oil compartment shall be connected to a separate conservator or segregated section of the main conservator of the transformer

The finish of internal walls of tank, covers, connecting boxes and cooling systems shall effectively protect against the effects of corrosion and the influence of the oil or synthetic liquid used in the transformer.

All pipes, radiators, stiffeners, or corrugations, which are welded to the tank wall, shall be welded externally, and shall be double welded wherever possible. All welds shall be stress relieved.

b. Pressure Relief Device

Pressure relief devices shall be fitted to the liquid immersed transformer. Pressure relief devices shall be, and not limited to the following:

- provided with a trip contact;
- resetting, rapid acting, relief valve type that has a mechanical operation indicator; and
- provided with facility for directing emissions of liquid from the relief device in the direction specified.

Proponents shall submit all test results of the pressure relief device with the bid document.

c. Oil Level Indication

The oil level marker shall be externally visible to the transformer's tank and in compliance with applicable ANSI/IEEE or IEC standards.

d. Marshalling Box

A metal enclosed, weather, vermin and dust proof marshalling box fitted with required glands, locks, glass door, terminal Board, heater with switch, illumination lamp with switch etc. shall be provided with the transformer to accommodate temperature indicators, terminal blocks etc. It shall have degree of protection of IP 55 or superior.

20. FITTINGS

The following minimum standard fittings shall be provided:

- rating, diagrams and terminal marking plate;
- tank grounding terminal;
- lifting lugs;
- pressure relief device; and
- drain/sampling valve with plug.

The fittings and accessories listed above are only indicative and any other fittings and accessories according to the applicable standards herein shall be equipped with the transformer.

21. TRANSFORMER OIL

The transformers shall comply with IEC 61099 for synthetic organic esters, IEC 60836 for silicon oil or as agreed for other liquids.

The transformer oil shall be non-corrosive on the basis of tests in accordance with IEC 62535.

The dielectric strength of the oil shall not be less than 40 kV.

The preferred transformer oil is Shell Diala S4 ZX-I or equivalent.

22. RATING AND CONNECTION PLATE

The transformer shall be provided with anodized aluminium laser engraved nameplate, in accordance with IEEE C57.12, Table 9 - Nameplate C.

The following plates, or an approved combined plate, shall be fixed to each transformer tank at an average height of 1500 mm above the ground level:

- A rating plate bearing the data specified in IEC 60076 Part 1. This plate shall also include the short circuit current rating, measured no load current and no-load losses at rated voltage and frequency, measured load losses at 75⁰ C (normal tap only) and D.C resistance of each winding at 75⁰ C.
- A diagram plate showing in an approved manner, the internal connections, and the voltage vector relationship of the several windings, in accordance with IEC 60076 Part 1 with the transformer voltage ratio for each tap and, in addition, a plan view of the transformer giving the correct physical relationship of the terminals.
- A plate showing the location and function of all valves and air release cocks or plugs. This plate shall also, if necessary, warn operators to refer to the Maintenance Instructions before applying vacuum.
- Plates are to be of stainless steel or other approved material capable of withstanding the rigours of continuous outdoor service at site.

Additionally, Bidders shall ensure that the following attributes are indicated on the aforementioned nameplate:

18. standard to which it is manufactured and tested;
19. identification of internal short-circuit and overload protection devices;
20. type of cooling (ONAN);
21. rated currents in A;
22. chopped wave (short time) impulse voltage withstand level in kV;

23. power frequency withstand voltage in kV;
24. percentage impedance at 65⁰C;
25. load loss in kW at rated current;
26. no-load loss in kW at rated voltage and frequency;
27. continuous ambient temperature at which ratings apply in ⁰C (40);
28. top oil and winding temperature rise at rated load in ⁰C;
29. winding connection diagram;
30. total mass (core, windings, and oil) in kg;
31. mass of core and windings in kg;
32. volume of oil in litres;
33. Oil with less than 2ppm of PCB; and
34. name of the purchaser (Property of Guyana Power & Light Inc.)

The nameplate shall meet Nameplate B per ANSI C57.12.00 and conform to the requirements of the section on Labels (see page 39) in this specification.

23. SURFACE TREATMENT

The transformer tank and all accessories shall be treated in accordance with applicable internal standard to ensure enclosure and equipment integrity.

24. TESTS

All transformers shall be subjected to routine tests including oil leakage tests, according to the relevant approved specifications at manufacturer's works. The transformers shall be subjected to pressure equal to the normal pressure plus 35 kN/m². This pressure shall be maintained for a period of not less than 48 hours during which no leakage whatsoever shall occur.

Tests shall also be conducted in accordance with the provisions of IEEE C57.12.91 and shall include, as a minimum, the following tests:

1. Ratio
2. Polarity
3. Phase Rotation
4. No-Load Loss
5. Excitation Current
6. Impedance Voltage
7. Load Loss
8. Applied Potential
9. Induced Potential
10. Impulse Test (typical data from previous unit is acceptable)
11. Temperature Test (typical data from previous unit is acceptable)
12. Sound Test (typical data from previous unit is acceptable)

The supplier shall make provision in his/her offer to bear all costs that are incurred in carrying out these tests to the satisfaction of GPL.

One set of certified test reports and oscillography shall be submitted for evaluation prior to dispatch of the equipment. The supplier shall also evaluate the test results and shall correct any defect indicated

25. COMPLIANCE WITH SPECIFICATION

The transformer shall comply in all respects with the requirements of this specification. However, any minor departure from the provisions of the specification shall be disclosed at the time of tendering in the Non-Compliance Schedule in this document (see page 41).

26. COMPLIANCE WITH REGULATIONS

All the transformers/equipment shall comply in all respects with the Laws of Guyana Governing the Importation of Commercial Items and/or Goods.

The equipment and connections shall be designed and arranged to minimize the risk of fire and any damage that might be caused in the event of a fire.

27. QUALITY ASSURANCE, INSPECTION AND TESTING

a. General

To ensure that the supply and services are in accordance with the Specification herein, with the regulations of Guyana and with relevant authorized international standards, the Proponent shall have in place suitable Quality Assurance Programmes and Procedures to ensure that all activities are being controlled and documented, as necessary.

The quality assurance arrangements shall conform to the relevant requirements of ISO 9001 or ISO 9002, as deemed appropriate by the Purchaser and the Proponent.

The systems and procedures that the Proponent will use to ensure that the supply complies with the specified requirements, shall be defined in the Proponent's Quality Plan.

The Proponent shall operate systems that implement the following:

Hold Point "A stage in the material procurement or workmanship process beyond which work shall not proceed without the documented approval of designated individuals or organisations."

The Purchaser's written approval is required to authorise work to progress beyond the Hold Points indicated in approved Quality Plans.

Notification Point "A stage in material procurement or workmanship process for which advance notice of the activity is required to facilitate witness."

If the Purchaser's representative does not attend after receiving documented notification in accordance with the agreed procedures and with the correct period of notice, then work may proceed.

b. Quality Assurance System

Unless the Proponent's Quality Assurance System has been audited and approved by the Purchaser, a Quality Assurance System shall be submitted to the Purchaser for approval within a minimum of One (1) month from the placement of order, or such other period as shall be agreed with the Purchaser. The Quality Assurance System shall provide a description of the Quality Control System for the supply and shall, unless advised otherwise, shall include, but not limited to the following details:

8. The structure of the organisation;
9. The duties and responsibilities assigned to staff to ensure quality of work;
10. The system for purchasing, taking delivery and verification of the specifications of raw materials;
11. The system for ensuring the quality of workmanship
12. The system for control of documentation;
13. The system for the retention of records; and
14. The arrangement for the Proponent's internal auditing.

c. Quality Plans

The Quality Plans shall set out the activities in a logical sequence and, unless advised otherwise, shall include, but limited to the following:

9. An outline of the proposed programme sequence;
10. The duties and responsibilities assigned to staff ensuring the quality of work;
11. Hold and notification points;
12. Submission of engineering documents required by the specification;
13. The inspection of materials and components on receipt;
14. Reference to the Supplier's procedures appropriate to each activity;
15. Inspection during fabrication and assembly; and
16. Final inspection and test.

d. Inspection and Testing

The Purchaser shall have free entry at all times, while work on the order is being performed, to all parts of the manufacturer's working area which are in relation to the processing of the transformers ordered. The Manufacturer/Proponent shall afford the Purchaser without charge, all reasonable facilities to assure that

the transformers being furnished are in accordance with the specifications herein.

The equipment shall have successfully passed all tests as described in Section 24 (see page 292).

The Purchaser reserves the right to reject an item of the transformer if the test results do not comply with the values specified herein.

Tests, including any retests required, shall be carried out by the Supplier at no extra charge, at the manufacturer's works.

Full details of the proposed methods of testing, including connection diagrams, shall be submitted to the Purchaser by the Supplier for approval, at least one month before testing.

All costs in connection with the testing, including any necessary re-testing, shall be borne by the Manufacturer/Proponent.

Any cost incurred by the Purchaser in connection with inspection and re-testing as a result of the failure of the transformer or any of its components under test or damage during transport or offloading shall be to the account of the Proponent.

The Proponent shall submit to the Purchaser three signed copies of the test certificates, giving the results of the tests as required. No materials shall be dispatched until the test certificates have been received by the Purchaser and the Proponent has been informed that they are acceptable.

The test certificates must show the actual values obtained from the tests, in the units used in this specification, and **not** merely confirm that the requirements have been met.

No inspection or lack of inspection or approval by the Purchaser's Representative of equipment or materials whether supplied by the Proponent or a Sub-Proponent, shall relieve the Proponent from his/her liability to complete the contracted works in accordance with the contract would exonerate him/her from any of his/her guarantees.

e. Guarantee

The Proponent shall guarantee the following:

- Quality and strength of materials used;

- Satisfactory operation during the guarantee period of one (1) year from the date of commissioning, or 18 months from the date of acceptance of the equipment by the Purchaser following delivery, whichever is the earlier. The Purchaser shall advise the Proponent of the date of commissioning;
- Performance figures as supplied by the Proponent in the Technical Data Schedule, the guaranteed copper and iron losses and other particulars;
- The offered surface treatment shall protect the treated metal from corrosion for a period of not less than ten (10) years from the date of delivery.

28. SPARE PARTS AND SPECIAL TOOLS

A list of spare parts (non-consumable items) and special tools necessary for commissioning, operation, and maintenance, where the need for such is specified by the manufacturer under the headings,

- Commissioning Spares; and
- Recommended Spares for 5 years.

The cost of Commissioning Spares will be included in the total price for the purpose of bid evaluation.

The cost of Recommended Spares parts will not be included in the total price for the purpose of bid evaluation. Spare parts shall be delivered suitably packed and clearly identified as to what they relate to and, where applicable, with a designation number corresponding to a drawing or corresponding to the spare parts list in the Operation and Maintenance instructions.

Proponent shall provide a priced list of all special tools and apparatus required for erection, commissioning, and maintenance of the equipment.

29. PACKING, SHIPPING AND DELIVERY

a. Delivery

The Supplier shall ensure safe transit from the Manufacturer's works to designated Warehouse and shall be responsible for all associated costs and expenses, including off-loading, delivery, and insurance.

Customs Clearance and Delivery from such Designated Warehouse to Site shall be carried out by GPL

at their expense.

b. Delivery Documentation

Delivery Documentation shall include the following, at a minimum:

- a clearly defined delivery docket number
- supplier's name;
- contract number / order no.
- quantity of material, description, and GPL Item No.
- packing list

A packing list in a sealed waterproof envelope shall accompany each case/drum or other delivery configuration.

Two copies of each packing list shall be sent to the Purchaser prior to dispatching the equipment/material.

c. Marking of Items

Each item/package shall be indelibly marked, on two sides - with the following:

- individual serial number;
- purchaser's name;
- contract number / order no.
- supplier's name;
- manufacturer's name;
- country of origin;
- description of contents; or
- conductor/cable details and length on drum
- case/drum measurements;
- gross and net weights;

- all necessary slinging and stacking instructions; and
- Delivery Schedule.

Bidders shall state and guarantee a delivery time from the date of receipt of an official order for the transformer and spares.

All apparatus shall be clearly labelled indicating, where necessary, its purpose and service positions.

The material of all labels and plates, their dimensions, legend, and the method of printing shall be subject to the approval of the Purchaser.

Colours shall be permanent and free from fading. All labels and plates for outdoor use shall be of non-corrosive material.

They shall be engraved in English. Nameplates shall carry all the applicable information specified in the applicable items of the Standards and other details as required in this specification. No scratching, corrections or changes will be allowed on nameplates.

Wherever possible the equipment shall carry the markings "**THIS EQUIPMENT IS PROPERTY OF GPL Inc.**".

30. GUARANTEE

The Supplier shall provide a guarantee which shall include the following:

- Satisfactory operation during the guarantee period of 24 months from the date of commissioning or 30 months from the date of shipment;
- Performance figures as supplied in the Technical Schedule; and
- No need for maintenance renewal of Corrosion Protection for at least five years from the date of delivery.

31. SUBMITTALS REQUIRED WITH THE BID

The following shall be required in duplicate of three (3) copies:

9. completed technical data schedule for each type and rating of the transformer;

10. descriptive literature giving full technical details of equipment offered;
11. Outline dimension drawings for each major component, general arrangement drawing showing component layout and general schematic diagrams;
12. type test certificates, where available, and sample routine test reports for each type and rating of the transformer;
13. summary reference list of customers already using equipment offered during the last 5 years with particular emphasis on units of similar design and rating;
14. details of manufacturer's quality assurance standards and programme and ISO 9000 series or equivalent national certification;
15. deviations from this specification. Only deviations approved in writing before placement of order shall be accepted; and
16. list of recommended spare parts and consumable items for five years of operation with prices and spare parts catalogue with price list for future requirements.

a. **DRAWINGS/DOCUMENTS:**

The following particulars shall be submitted with the Bid:

1. General outline drawing showing shipping dimensions and overall dimensions, net weights and shipping weights, quality of insulating oil, location of coolers, marshalling box and tap changers etc.;
2. Assembly drawings of core, windings etc. and weights of main components/parts;
3. Height of centre line on HV and LV connectors of transformers from the rail top level;
4. Dimensions of the largest part to be transported;
5. GA drawings/details of various types of bushing;
6. Tap changing and Name Plate diagram;
7. Type test certificates of similar transformers;

8. Illustrative & descriptive literature of the Transformer and
9. Maintenance and Operating Instructions.

32. SUBMITTALS AFTER CONTRACT AWARD

A. Technical Folders – Hard Copy

The Purchaser shall nominate items of equipment for which the Supplier shall provide two bound Folders of Technical Particulars. Information in respect of each nominated item shall include the following, insofar as applicable:

1. Descriptive literature giving full technical details;
2. Detailed dimensioned drawing;
3. Installation, Commissioning and Operation and Maintenance Instructions;
4. Manufacturers Recommendations regarding spares:
 - a. Commissioning spares
 - b. O&M parts.
 - c. Special tools and equipment required for erection, commissioning, and maintenance.
5. A Schedule of all special tools and equipment required for erection, commissioning, and maintenance of the equipment.
6. Calculations validating the Design (If requested by the Purchaser)
7. Technical data schedule, with approved revisions
8. Inspection and test reports carried out in the manufacturer's works;

Such folders shall be subject to approval by the Purchaser, who shall reserve the right to call for additional information/data, if in his/her opinion such is required.

B. Technical Folders – Electronic Version

Suppliers shall provide an Electronic Version of the Technical Folders in addition to the hard copy.

C. Drawings and Documentation

1. Schedule for the Production of Drawings

Within 10 days of placement of order, the Supplier shall submit for approval by the Purchaser, a schedule of the drawings to be produced. The schedule shall also provide a program of drawing submittals.

2. Drawings and Document Formats

All detail drawings submitted for approval shall be to scale not less than 1:20. All the important dimensions shall be given and the material of which each part is to be constructed shall be indicated on the drawings. All documents and drawings shall become the property of the Purchaser.

All drawings and calculations, submitted to the Purchaser, shall be on international standard size paper, A0, A1, A2, A3 or A4. All such drawings and calculations shall be provided with a contract title block, which shall include the name of the Purchaser and shall be assigned a unique drawing number.

Lettering sizes and thickness of lettering and lines be selected so that if reduced by two stages to one quarter of their size, the alphanumeric characters and lines are still perfectly legible so as to enable them to be microfilmed.

For presentation of design drawings and circuit documents, IEC Publication 60617 or equivalent standards for graphical symbols are to be followed.

3. Approval Procedures

The Supplier shall submit all drawings, documents, and type test reports for approval in sufficient time to permit modifications to be made if such are deemed necessary and re-submit them for approval without delaying the initial deliveries or completion of the supply. The Purchaser shall endeavor to return them within a period of two weeks from the date of receipt.

Three copies of all drawings shall be submitted for approval and three copies for any subsequent revision. The Purchaser reserves the right to request any further additional information/data that may be considered necessary to fully review the drawings. If the Purchaser is satisfied with the drawing, one copy will be returned to the Supplier marked with "Approved" stamp. If the Purchaser is not totally satisfied with the drawing, then

“Approved Subject to Comment” status will be given to it and a comment sheet will be sent to the Supplier. If the drawing submitted does not comply with the requirements of the specification, then it will be given “Not Approved” status and a comment sheet will be sent to the Supplier. In both these cases the Supplier will have to modify the drawing, update the revision column, and resubmit for final approval. Following approval, ten copies of the final drawings will be required by the Purchaser.

Any drawing or document submitted for information only should be indicated as such by the Supplier. Drawings and documents submitted for information only will not be returned to the Supplier unless the Purchaser considers that such drawing needs to be approved, in which case they will be returned suitably stamped with comments.

The Supplier shall be responsible for any discrepancies or errors in or omissions from the drawings, whether such drawings have been approved or not by the Purchaser. Approval given by the Purchaser to any drawing shall not relieve the Supplier from his liability to complete the supply in accordance with this specification and the conditions of contract nor exonerate him from any of his guarantees.

4. Electronic Versions of the Drawings & Documentation

Electronic versions of drawings and documentation shall be provided.

14. COMPLETENESS OF SUPPLY

All accessories or fittings not specifically mentioned in the Specification, but which are necessary or usual for similar equipment and for its efficient performance shall be included in the Bid along with full details and price. The attention of the Purchaser should be drawn to it.

33. NON-COMPLIANCE SCHEDULE

On this schedule, the Proponent shall provide a list of non-compliance with this specification, documenting the effects that such non-compliance is likely to have on the transformer/equipment/component life span and operating characteristics. Each non-compliance shall be referred to the relevant specification clause.

Clause No.	Non-Compliance

34. TEST CERTIFICATE SCHEDULE

On this schedule, a list of the test certificates shall be included with the bid. This list shall include the certificates for the type tests and sample routine test reports. Each certificate listed shall be referred to the relevant specification clause.

Clause No.	Type Test Certificate or Routine Test Report

35. TECHNICAL DATA SCHEDULE FOR 16.7, 20 and 35MVA, 13.8/69KV THREE PHASE POWER TRANSFORMER

For submission(s) to be evaluated, Proponent **MUST** complete the form below.

Item No.	Description	Unit	GPL	Bidder
1	Rated Power (kVAn - ONAN Rated)	kVA	16,700	
2	Rated Frequency	Hz	60	
3	Rated Primary Voltage	kV	69	
4	Rated Secondary Voltage	V	13,800	
5	Number of Phases		3	
6	Transformer Type		Oil Immersed	
7	HV – LV Vector Group		YNd11	
8	Cooling Type		ONAN	
9	No. of Tap Positions/Steps	No.	13	
10	Max Tap Position (above nominal)	%	5	
11	Min Tap Position (below nominal)	%	-10	
12	Tap Steps	%	1.25	
13	Magnetic Flux Density (one minute at normal tap) (20% overvoltage at 95% of rated frequency)	Tesla	1.5	
14	No Load Current	A	(1% to 2%) x In	
15	No-load Loss at Nominal Tap Position and Rated Primary Voltage	kW	(0.08% to 0.1%) x kVAn x 0.8	
16	Load Loss at Nominal Tap Position and Rated Load Current	kW	(0.38% to 0.48%) x kVAn x 0.8	
17	Voltage Regulation at Full Load and Power Factor of 1	%	<=1	
18	Voltage Regulation at Full Load and Power Factor of 80%	%	<1.25	
19	Rated Short-circuit withstand Current (HV side/ MV side)	kA	40/65	
20	Rated Short-circuit Current withstand duration (both sides)	s	10	
21	Impedance measured at 65 °C and nominal tap position	%	11.48	
22	X/R Ratio	%	18.6	
23	Type of Winding material on HV Side (Copper is the preferred material type)	...	Copper	
24	Type of Winding material on LV Side (Copper is the preferred material type)	...	Copper	
25	Connections - HV windings		Wye with	

Item No.	Description	Unit	GPL	Bidder
			neutral	
26	Connections - MV windings		Delta	
Transformer Oil				
27	Oil type		Shall comply with IEC 61099 for synthetic organic esters, IEC 60836 for silicon oil	
28	Dielectric strength of the oil	kV	>40	
Overloading				
29	Duration of 25% Overload at Service Conditions	minutes	180	
30	Duration of 50% Overload at Service Conditions	minutes	90	
Temperature Rise				
31	Design maximum outdoor temperature	°C	40	
32	Design continuous ambient temperature	°C	35	
33	Minimum ambient temperature	°C	15	
34	Maximum temperature rise over ambient temperature:			
	a) In oil by thermometer	°C	65	
	b) In winding by resistance measurement	°C	65	
	c) Limit for hot spot temperature for which the transformer is designed	°C	<80	
	d) Temperature gradient between windings and oil	°C	20	
	e) Type and details of winding hot spot temperature detector		Resistance temperature detector	
	f) Type of maximum winding temperature indicator		analog/ digital	
35	Average Winding Temperature Rise	°C	65	
36	Maximum Winding Temperature Rise	°C	105	
General Transformer Data				
37	Manufacturer	...		
38	Type		double wound, sealed type, oil immersed with natural oil cooling	
39	Operating flux density	Tesla	1.15	
40	Manufacturer's data sheet supplied	YES/NO	YES	

Item No.	Description	Unit	GPL	Bidder
Windings/Coils				
41	Conductor for HV Winding - Manufacturer/Supplier			
42	Conductor Material for HV Winding		Copper	
43	Conductor for MV Winding - Manufacturer/Supplier			
44	Conductor Material for MV Winding		Copper	
Bushings & Terminals				
45	Type of bushing insulator - HV		porcelain	
46	Type of bushing insulator - MV		porcelain	
47	Type of bushing insulator - Neutral		porcelain	
48	Voltage rating HV Bushing	kV	82.8	
49	Voltage rating MV Bushing	kV	17.5	
50	Current rating HV Bushing	A	2 x In of transformer	
51	Current rating MV Bushing	A	2 x In of transformer	
52	HV Bushing BIL	kV	350	
53	HV Busing Power Frequency withstand Voltage - Dry	kV	160	
54	HV Busing Power Frequency withstand Voltage - Wet	kV	140	
55	Type and Metal used in HV Terminal			
56	MV Busing Power Frequency withstand Voltage - Dry	kV	36	
57	MV Busing Power Frequency withstand Voltage - Wet	kV	30	
58	Type and Metal used in MV Terminal			
59	Type and Metal used in Earth Terminal			
60	Busing Type		outdoor type and easily replaceable	
61	Creepage Distance (minimum) line to line	mm/kV	25	
62	Creepage Distance (minimum) line to ground	mm/kV	44	
Bushing Clearance				
63	Minimum phase to phase clearance HV	mm	700	
64	Minimum earth to phase clearance	mm	700	
65	Minimum phase to phase clearance MV	mm	200	
66	Spring and lock washer included	YES/NO	YES	
Tap Changer				
67	Tap Changer Catalogue Details Attached	YES/NO	YES	
68	Can the Tap Changer switch be Locked	YES/NO	YES	
Details of CT in the Bushing to be provided :				

Item No.	Description	Unit	GPL	Bidder
69	MV CT		2000:5 0.5/5P20 20VA/20VA	
70	HV CT		600:5 0.5/5P20 20VA/20VA	
71	HV - Neutral CT		200:5 0.5/5P20 20VA/20VA	
Tank				
72	Tank material		construction steel	
73	Thickness of the metal sheet	mm	≥11	
74	Painting method details attached	YES/NO	YES	
Tank (for information purposes only)				
75	Tank Width	mm		
76	Tank Height	mm		
77	Tank Dept (length)	mm		
78	Weight of Core and Windings	kg		
79	Weight of Tank	kg		
80	Weight of Oil at 20 °C	kg		
81	Total weight of Transformer without oil	kg		
82	Shipping weight of Transformer	kg		

Name:.....

Affix Company Seal
Below

Signature.....

Date.....

Item No.	Description	Unit	GPL	Bidder
1	Rated Power (kVAn - ONAN Rated)	kVA	20,000	
2	Rated Frequency	Hz	60	
3	Rated Primary Voltage	kV	69	
4	Rated Secondary Voltage	V	13,800	
5	Number of Phases		3	
6	Transformer Type		Oil Immersed	
7	HV – LV Vector Group		YNd11	
8	Cooling Type		ONAN	
9	No. of Tap Positions/Steps	No.	13	
10	Max Tap Position (above nominal)	%	5	
11	Min Tap Position (below nominal)	%	-10	
12	Tap Steps	%	1.25	
13	Magnetic Flux Density (one minute at normal tap) (20% overvoltage at 95% of rated frequency)	Tesla	1.5	
14	No Load Current	A	(1% to 2%) x In	
15	No-load Loss at Nominal Tap Position and Rated Primary Voltage	kW	(0.08% to 0.1%) x kVAn x 0.8	
16	Load Loss at Nominal Tap Position and Rated Load Current	kW	(0.38% to 0.48%) x kVAn x 0.8	
17	Voltage Regulation at Full Load and Power Factor of 1	%	<=1	
18	Voltage Regulation at Full Load and Power Factor of 80%	%	<1.25	
19	Rated Short-circuit withstand Current (HV side/ MV side)	kA	40/65	
20	Rated Short-circuit Current withstand duration (both sides)	s	10	
21	Impedance measured at 65 °C and nominal tap position	%	11.29	
22	X/R Ratio	%	18.6	
23	Type of Winding material on HV Side (Copper is the preferred material type)	...	Copper	
24	Type of Winding material on LV Side (Copper is the preferred material type)	...	Copper	
25	Connections - HV windings		Wye with neutral	
26	Connections - MV windings		Delta	
	Transformer Oil			

Item No.	Description	Unit	GPL	Bidder
27	Oil type		Shall comply with IEC 61099 for synthetic organic esters, IEC 60836 for silicon oil	
28	Dielectric strength of the oil	kV	>40	
Overloading				
29	Duration of 25% Overload at Service Conditions	minutes	180	
30	Duration of 50% Overload at Service Conditions	minutes	90	
Temperature Rise				
31	Design maximum outdoor temperature	°C	40	
32	Design continuous ambient temperature	°C	35	
33	Minimum ambient temperature	°C	15	
34	Maximum temperature rise over ambient temperature:			
	a) In oil by thermometer	°C	65	
	b) In winding by resistance measurement	°C	65	
	c) Limit for hot spot temperature for which the transformer is designed	°C	<80	
	d) Temperature gradient between windings and oil	°C	20	
	e) Type and details of winding hot spot temperature detector		Resistance temperature detector	
	f) Type of maximum winding temperature indicator		analog/ digital	
35	Average Winding Temperature Rise	°C	65	
36	Maximum Winding Temperature Rise	°C	105	
General Transformer Data				
37	Manufacturer	...		
38	Type		double wound, sealed type, oil immersed with natural oil cooling	
39	Operating flux density	Tesla	1.15	
40	Manufacturer's data sheet supplied	YES/NO	YES	
Windings/Coils				
41	Conductor for HV Winding - Manufacturer/Supplier			

Item No.	Description	Unit	GPL	Bidder
42	Conductor Material for HV Winding		Copper	
43	Conductor for MV Winding - Manufacturer/Supplier			
44	Conductor Material for MV Winding		Copper	
Bushings & Terminals				
45	Type of bushing insulator - HV		porcelain	
46	Type of bushing insulator - MV		porcelain	
47	Type of bushing insulator - Neutral		porcelain	
48	Voltage rating HV Bushing	kV	82.8	
49	Voltage rating MV Bushing	kV	17.5	
50	Current rating HV Bushing	A	2 x In of transformer	
51	Current rating MV Bushing	A	2 x In of transformer	
52	HV Bushing BIL	kV	350	
53	HV Busing Power Frequency withstand Voltage - Dry	kV	160	
54	HV Busing Power Frequency withstand Voltage - Wet	kV	140	
55	Type and Metal used in HV Terminal			
56	MV Busing Power Frequency withstand Voltage - Dry	kV	36	
57	MV Busing Power Frequency withstand Voltage - Wet	kV	30	
58	Type and Metal used in MV Terminal			
59	Type and Metal used in Earth Terminal			
60	Busing Type		outdoor type and easily replaceable	
61	Creepage Distance (minimum) line to line	mm/kV	25	
62	Creepage Distance (minimum) line to ground	mm/kV	44	
Bushing Clearance				
63	Minimum phase to phase clearance HV	mm	700	
64	Minimum earth to phase clearance	mm	700	
65	Minimum phase to phase clearance MV	mm	200	
66	Spring and lock washer included	YES/NO	YES	
Tap Changer				
67	Tap Changer Catalogue Details Attached	YES/NO	YES	
68	Can the Tap Changer switch be Locked	YES/NO	YES	
Details of CT in the Bushing to be provided :				
69	MV CT		2000:5 0.5/5P20 20VA/20VA	

Item No.	Description	Unit	GPL	Bidder
70	HV CT		600:5 0.5/5P20 20VA/20VA	
71	HV - Neutral CT		200:5 0.5/5P20 20VA/20VA	
Tank				
72	Tank material		construction steel	
73	Thickness of the metal sheet	mm	≥11	
74	Painting method details attached	YES/NO	YES	
Tank (for information purposes only)				
75	Tank Width	mm		
76	Tank Height	mm		
77	Tank Dept (length)	mm		
78	Weight of Core and Windings	kg		
79	Weight of Tank	kg		
80	Weight of Oil at 20 °C	kg		
81	Total weight of Transformer without oil	kg		
82	Shipping weight of Transformer	kg		

Name:.....

Affix Company Seal
Below

Signature:.....

Date:.....

Item No.	Description	Unit	GPL	Bidder
1	Rated Power (kVAn - ONAN Rated)	kVA	35,000	
2	Rated Frequency	Hz	60	
3	Rated Primary Voltage	kV	69	
4	Rated Secondary Voltage	V	13,800	
5	Number of Phases		3	
6	Transformer Type		Oil Immersed	
7	HV – LV Vector Group		YNd11	
8	Cooling Type		ONAN	
9	No. of Tap Positions/Steps	No.	13	
10	Max Tap Position (above nominal)	%	5	
11	Min Tap Position (below nominal)	%	-10	
12	Tap Steps	%	1.25	
13	Magnetic Flux Density (one minute at normal tap) (20% overvoltage at 95% of rated frequency)	Tesla	1.5	
14	No Load Current	A	(1% to 2%) x In	
15	No-load Loss at Nominal Tap Position and Rated Primary Voltage	kW	(0.08% to 0.1%) x kVAn x 0.8	
16	Load Loss at Nominal Tap Position and Rated Load Current	kW	(0.38% to 0.48%) x kVAn x 0.8	
17	Voltage Regulation at Full Load and Power Factor of 1	%	<=1	
18	Voltage Regulation at Full Load and Power Factor of 80%	%	<1.25	
19	Rated Short-circuit withstand Current (HV side/ MV side)	kA	40/65	
20	Rated Short-circuit Current withstand duration (both sides)	s	10	
21	Impedance measured at 65 °C and nominal tap position	%	10.9	
22	X/R Ratio	%	27.3	
23	Type of Winding material on HV Side (Copper is the preferred material type)	...	Copper	
24	Type of Winding material on LV Side (Copper is the preferred material type)	...	Copper	
25	Connections - HV windings		Wye with neutral	
26	Connections - MV windings		Delta	
	Transformer Oil			

Item No.	Description	Unit	GPL	Bidder
27	Oil type		Shall comply with IEC 61099 for synthetic organic esters, IEC 60836 for silicon oil	
28	Dielectric strength of the oil	kV	>40	
Overloading				
29	Duration of 25% Overload at Service Conditions	minutes	180	
30	Duration of 50% Overload at Service Conditions	minutes	90	
Temperature Rise				
31	Design maximum outdoor temperature	°C	40	
32	Design continuous ambient temperature	°C	35	
33	Minimum ambient temperature	°C	15	
34	Maximum temperature rise over ambient temperature:			
	a) In oil by thermometer	°C	65	
	b) In winding by resistance measurement	°C	65	
	c) Limit for hot spot temperature for which the transformer is designed	°C	<80	
	d) Temperature gradient between windings and oil	°C	20	
	e) Type and details of winding hot spot temperature detector		Resistance temperature detector	
	f) Type of maximum winding temperature indicator		analog/ digital	
35	Average Winding Temperature Rise	°C	65	
36	Maximum Winding Temperature Rise	°C	105	
General Transformer Data				
37	Manufacturer	...		
38	Type		double wound, sealed type, oil immersed with natural oil cooling	
39	Operating flux density	Tesla	1.15	
40	Manufacturer's data sheet supplied	YES/NO	YES	
Windings/Coils				
41	Conductor for HV Winding - Manufacturer/Supplier			
42	Conductor Material for HV Winding		Copper	

Item No.	Description	Unit	GPL	Bidder
43	Conductor for MV Winding - Manufacturer/Supplier			
44	Conductor Material for MV Winding		Copper	
Bushings & Terminals				
45	Type of bushing insulator - HV		porcelain	
46	Type of bushing insulator - MV		porcelain	
47	Type of bushing insulator - Neutral		porcelain	
48	Voltage rating HV Bushing	kV	82.8	
49	Voltage rating MV Bushing	kV	17.5	
50	Current rating HV Bushing	A	2 x In of transformer	
51	Current rating MV Bushing	A	2 x In of transformer	
52	HV Bushing BIL	kV	350	
53	HV Busing Power Frequency withstand Voltage - Dry	kV	160	
54	HV Busing Power Frequency withstand Voltage - Wet	kV	140	
55	Type and Metal used in HV Terminal			
56	MV Busing Power Frequency withstand Voltage - Dry	kV	36	
57	MV Busing Power Frequency withstand Voltage - Wet	kV	30	
58	Type and Metal used in MV Terminal			
59	Type and Metal used in Earth Terminal			
60	Busing Type		outdoor type and easily replaceable	
61	Creepage Distance (minimum) line to line	mm/kV	25	
62	Creepage Distance (minimum) line to ground	mm/kV	44	
Bushing Clearance				
63	Minimum phase to phase clearance HV	mm	700	
64	Minimum earth to phase clearance	mm	700	
65	Minimum phase to phase clearance MV	mm	200	
66	Spring and lock washer included	YES/NO	YES	
Tap Changer				
67	Tap Changer Catalogue Details Attached	YES/NO	YES	
68	Can the Tap Changer switch be Locked	YES/NO	YES	
Details of CT in the Bushing to be provided :				
69	MV CT		2000:5 0.5/5P20 20VA/20VA	

Item No.	Description	Unit	GPL	Bidder
70	HV CT		600:5 0.5/5P20 20VA/20VA	
71	HV - Neutral CT		200:5 0.5/5P20 20VA/20VA	
Tank				
72	Tank material		construction steel	
73	Thickness of the metal sheet	mm	≥11	
74	Painting method details attached	YES/NO	YES	
Tank (for information purposes only)				
75	Tank Width	mm		
76	Tank Height	mm		
77	Tank Dept (length)	mm		
78	Weight of Core and Windings	kg		
79	Weight of Tank	kg		
80	Weight of Oil at 20 °C	kg		
81	Total weight of Transformer without oil	kg		
82	Shipping weight of Transformer	kg		

SIGNATURE OF BIDDER/TENDERER: _____

Affix Company Seal Below

DESIGNATION: _____

NAME OF BIDDER/TENDERER: _____

DATE: _____

BID Delivery Schedule

Supply of:

20 and 35 MVA ONAN Rated Three Phase Power Transformers & 35 MVA Mobile Substation

IFB # GPL-PD-002-2022

Description	Named place of Destination as stated in the bid document	Earliest Delivery Date	Latest Delivery Date	Bidders offered Delivery date (to be specified by the bidder)	Bid Security required
Supply of 20 and 35 MVA ONAN Rated Three Phase Power Transformers & 35 MVA Mobile Substation	Georgetown Guyana	Immediately after signing of Contract or receipt of Purchase Order	Eight weeks after the signing of the contract or the receipt of the purchase order.		2 % of Bid Price

QUALIFICATION INFORMATION

1. For individual bidders or individual members of a joint venture

1.1 Legal status of Bidder (*attach copy*).

Place of registration: _____

Principal kind of business: _____

Power of attorney for signing the Bid (*attach*).

1.2 Total volume of supplies executed for the last three (3) years in Guyana dollars or currency of bid:

_____ in 20__.

_____ in 20__.

_____ in 20__.

1.3 Supplies of a similar nature executed by the Supplier during the last two years (*not less than three (3) supplies*)

№	Name of Goods	Name of Clients, address and telephone	Contract Price

1.4 Copies of financial reports for the last three years (*balance sheets, loss and profit statements, auditors' reports, etc.*). List below and attach copies.

3.5 Evidence of access to financial resources (*cash in hand, lines of credit, overdraft facility etc.*). List below and attach copies of supporting documents.

3.6 Evidence of compliance with NIS, IRD and TIN Certificate and VAT Registration for Vatable item/s. (*attach supporting documents*).

3.7 Information on all claims, arbitration or other legal proceedings currently being examined or already settled.

2.0 Any other information required by the Procuring Entity to execute the Contract

2.1 The Supplier certifies that he meets all the qualification criteria and requirements, in accordance with normative legal documents.

I certify the authenticity of all the above information.

(Full name)

(Title)

(Signature and seal)

Dated on: _____ day of _____ 20__.

(Date)

SUPPLIER'S BID

Date: _____
IFB No: _____

TO: _____
(Name and address of Procuring Entity)

Dear Sir / Madam,

Having examined the bidding documents, including the Annexes and Addenda No _____ [*specify number*], the receipt of which is hereby acknowledged, we, the undersigned, offer to supply and provide _____ [*description of goods and related services*] in accordance with the requirements of the bidding documents to the total sum of _____ [*Total Amount of Bid in Words and Figures*], confirmed by the attached Price Schedule which is a part of this Bid.

- (a) We, including all subcontractors, regarding any part of the Contract, in accordance with the bidding documents, have no conflict of interests pursuant to sub clause 2 (i) of the Instructions to Bidders;
- (b) We, including all subcontractors, regarding any part of the Contract, in accordance with the bidding documents, have not been declared by the [authorized State body] [National Board] on procurement to be ineligible, or are not ineligible, in accordance with the legislation of Guyana.

We undertake, if our Bid is accepted, to supply the Goods, in accordance with a delivery schedule given in the Schedule of Requirements.

If our Bid is accepted, we undertake to furnish the Performance security in the form of _____ to the amount of _____, comprising _____% of the Contract Price in order to execute the Contract properly and within the time period(s) specified in the Bidding Documents.

We hereby confirm that this bid shall be valid during _____ days starting from the date established for bid opening, and it shall be binding until the expiry of the indicated period.

Prior to the preparation and execution of a formal Contract, this Bid together with your written confirmation of its acceptance shall form a binding Contract on the parties.

We understand that you are not bound to accept the lowest or any bid you receive.

Dated _____.

Duly authorized to sign the Bid _____
(Name of Supplier)

Supply Contract

THIS CONTRACT made the _____ day of _____ 20__

Between _____ [name of Procuring Entity] (hereinafter referred to as "the Procuring Entity"), on the one hand, and _____ [name of Supplier] from _____ [city and country of Supplier] (hereinafter referred to as "the Supplier"), on the other hand have come to an Agreement on the following:

The Procuring Entity has announced bid for procurement of goods and services, namely _____ [brief description of goods and related services] and has accepted the Supplier's bid for the supply of indicated goods and services to the sum of _____ [Contract Price in words and figures] (hereinafter referred to as "the Contract Price").

THIS CONTRACT WITNESSES AS FOLLOWS:

1. In this Contract, the terms and expressions have the same meanings as are respectively assigned to them in the Conditions of Contract referred to.
4. The following documents shall form the Contract and shall be deemed its integral part, viz.:
 - (a) Procuring Entity's Notification of Award;
 - (b) Bid and Price Schedule submitted by Bidder;
 - (c) Schedule of Requirements;
 - (d) Technical Specifications;
 - (e) General Conditions of Contract;
 - (f) Special Conditions of Contract;
 - (g) Other documents included in the Contract documents;
5. This Contract shall prevail over all other Contract documents. In the event of any discrepancy or inconsistency within the Contract documents, then the documents shall prevail in the order listed above.
6. In consideration of the payments to be made by the Procuring Entity to the Supplier as hereinafter mentioned, the Supplier hereby covenants with the Procuring Entity to provide the Goods and Services, and remedy defects therein in conformity in all respects with the provisions of the Contract.
7. The Procuring Entity hereby agrees to pay the Supplier in consideration of the delivery of the Goods and Services and the remedying of defects therein, the Contract Price or such other sum as may become payable under the provisions of the Contract at the times and in the manner prescribed by the Contract

IN WITNESS of the foresaid, the parties hereto have caused this Contract to be executed in accordance with the legislation of Guyana the day and year first above written in the beginning of the document.

For and on behalf of the Procuring Entity:

Signed by _____

Witnesses:

1. _____

2. _____

For and on behalf of the Contractor:

Signed by _____

Witnesses:

1. _____

2. _____

BID SECURITY
(Bank Guarantee)

Whereas _____ [*name of Bidder*] (hereinafter referred as "the Bidder") is ready to submit his bid dated _____ [*date of bid submission*] for the supply _____ [*name and/or description of goods*] (hereinafter referred as "the Bid"),

KNOW ALL PEOPLE, that WE _____ [*name of Bank*] from _____ [*name of country*], having our registered office at the address _____ [*address of Bank*], (hereinafter referred as "the Bank"), are bound to _____ [*name of Procuring Entity*] to the sum of _____, by which payment to the indicated Procuring Entity shall be made in whole and in a timely manner; the Bank is bound on behalf of its name, its successors and authorized persons. This is to confirm that the license issued to the Bank shall provide for activity on issuance of the guarantee, and the person(s) signing that guarantee is entitled to act on behalf of the Bank, and if the approval of Board of Directors, or of General Stockholders Meeting is required, it is already received and there is no other approval required.

THE CONDITIONS of this obligation are as follows:

1. If the Bidder:
 - (a) Withdraws his Bid during the period of bid validity specified by the Bidder on the Form of Bid; or
2. If the Bidder having received notice from the Procuring Entity that his bid is accepted within the period of bid's validity:
 - (a) fails or rejects to sign the Contract at the request of; or
 - (b) fails or rejects to furnish the performance security in accordance with the Instructions to Bidders;

We undertake to pay the Procuring Entity the above sum upon receipt of his first written request, without needing the Procuring Entity to show grounds or reasons of that request, provided that the sum requested by the Procuring Entity is due to him because of the occurrence of one or two or both conditions, specifying the condition or conditions occurred.

This guarantee shall remain in force during _____ days inclusive following the expiry of the bid validity period, and any request in respect thereof should reach the Bank not later than the abovementioned date.

(Full name of Bank's representative)

(Title)

(Signature and seal)

Dated on « ____ » day of _____ 20__.

Bid-Securing Declaration –Not Applicable

[The Bidder shall fill in this Form if applicable pursuant to BDS.]

Date: _____

IFB No.: _____

Alternative No.: _____

To: _____

We, the undersigned, declare that:

1. We understand that, according to your conditions, bids must be supported by a Bid-Securing Declaration.
2. We accept that we will automatically be suspended from being eligible for bidding in any contract with the Purchaser for the period of time of _____ *[insert number of months or years]* starting on _____ *[insert date]*, if we are in breach of our obligation(s) under the bid conditions, because we:
 - (a) have withdrawn our Bid during the period of bid validity specified by us in the Bidding Data Sheet; or
 - (b) having been notified of the acceptance of our Bid by the Purchaser during the period of bid validity, (i) fail or refuse to execute the Contract, if required, or (ii) fail or refuse to furnish the Performance Security, in accordance with the ITB.
3. We understand this Bid Securing Declaration shall expire if we are not the successful Bidder, upon the earlier of (i) our receipt of a copy of your notification of the name of the successful Bidder; or (ii) twenty-eight days after the expiration of our Bid.
4. We understand that if we are a Joint Venture, the Bid Securing Declaration must be in the name of the Joint Venture that submits the bid. If the Joint Venture has not been legally constituted at the time of bidding, the Bid Securing Declaration shall be in the names of all future partners as named in the letter of intent.

Signed: _____ *[insert signature of person whose name and capacity are shown]* In the

capacity of _____ *[insert legal capacity of person signing the Bid Securing Declaration]*

Name: _____ *[insert complete name of person signing the Bid Securing Declaration]*

Duly authorized to sign the bid for and on behalf of: *[insert complete name of Bidder]*

Dated on _____ day of _____, _____ *[insert date of signing]*

Manufacturer's Authorization

*[The Bidder shall require the Manufacturer to fill in this Form in accordance with the instructions indicated. This letter of authorization should be on the letterhead of the Manufacturer and should be signed by a person with the proper authority to sign documents that are binding on the Manufacturer. The Bidder shall include it in its bid, if so indicated in the **BDS.**]*

Date of Bid Submission(<i>day/ month/ year</i>):
IFB No: <i>[insert number of bidding process]</i>
Alternative No.: <i>[insert identification No if this is a Bid for an alternative]</i>

To: _____ *[insert complete name of Purchaser]*

WHEREAS

We _____ *[insert complete name of Manufacturer]*, who are official manufacturers of _____ *[insert type of goods manufactured]*, having factories at _____ *[insert full address of Manufacturer's factories]*, do hereby authorize _____ *[insert complete name of Bidder]* to submit a bid the purpose of which is to provide the following Goods, manufactured by us _____ *[insert name and or brief description of the Goods]*, and to subsequently negotiate and sign the Contract.

We hereby extend our full guarantee and warranty in accordance with Clause 1.3 of the General Conditions of Contract, with respect to the Goods offered by the above firm.

Signed: _____ *[insert signature(s) of authorized representative(s) of the Manufacturer]*

Name: _____ *[insert complete name(s) of authorized representative(s) of the Manufacturer]*

Title: _____ *[insert title]*

Duly authorized to sign this Authorization on behalf of: _____ *[insert complete name of Bidder]*

Dated on _____ day of _____, 20____ *[insert date of signing]*

Letter of Acceptance
(Letterhead paper of Procuring Entity)

Date: _____

To: _____
(Name of Supplier)

(Address of Supplier)

We hereby notify you that your bid dated the ____ day of _____ 20__, for the supply of goods _____ (*description of goods*) up to a total of _____
(*Amount in figures and words*)

as amended and modified in accordance with the Instructions to Bidders is hereby accepted by our agency.

Simultaneously, we send you the Form of Contract and request you, pursuant to Clause 20.1 of the Instructions to Bidders, during seven (7) days to sign and date the Form of Contract, and return it at our address. Jointly with the signed Contract, we request you to furnish the performance security, in accordance with ITB Clause 20.2.

You hereby entrusted to start supply of the Goods, in accordance with the terms and conditions of a Contract.

Name of agency _____

Full name and Title _____

Signature of Authorized Representative _____

Power of Attorney

TO: _____ *[name of Procuring Entity]*

WHEREAS _____ *[name of Supplier]*, who is
the Supplier _____ *[name and/or description of goods]*.

do hereby authorize _____ *[name and address of Supplier's
Representative]* to submit the Bid, and sign the Contract based on *Invitation for Bids* for the abovementioned
goods to be supplied by us, and

[Full name, title, signature for and on behalf of Supplier]

Dated on « _____ » day of _____ 20__ (Seal)
(Date)

Note: The power of attorney must be drafted on a letterhead paper of the Supplier, and signed by a competent
person authorized by the Supplier. The Bidder shall include this power of attorney in his Bid.

Evaluation Criteria

EVALUATION CRITERIA			
NON-FINANCIAL ASSESSMENT	COMPULSORY REQUIREMENT	RESPONSIVE	
		Yes	No
	Submission of Valid Company Registration		
	Submission of Valid Certificate of Compliance – GRA		
	Submission of Valid Certificate of Compliances – NIS		
	Completion of Form of Tender (signed)		
	Audited Financial Statement from a Registered Chartered Accountant/Accounting Firm		
	Record of Past Experience or Similar Works		
	Submit statement of any or no Litigation against company		
	Bid Security in the amount required		

Evaluation Criteria

1. Evaluation Criteria

Points will be award to bidders. The bidder with the highest points will be awarded the project. The points are split between X-points, tendered price and Y-points, other adequacies equally, as follows:

X-Points (40 Points):

Lowest Bid (Tender Price) – 30 Points

Financial Adequacy – 10 Points

Y- Points (60 points)

Technical Adequacy – 50 points

Delivery Time – 10 points

X-points

Max Score attained from sum of Formula 1 (30 point Max) and Table 1 (10 points Max) Score

Lowest Tendered Price (Max – 30 Points)

The X-points is calculated using the following ;

Formula 1

$$X = \frac{\text{Lowest Tendered Price}}{\text{Tendered Price}} \times 30$$

Financial Adequacy (Max -10 points):

Table No.1 = 10 points

The financial adequacy is based on the financial resources, available to the bidder.

Credit available as percentage of bid price	Points gained(Max 10 Points)
>50%	10
40-50	8
30-40	6
20-30	4
<20	2

Table 1 – Financial assessment based on credit available

A penalty of immediate rejection of a proposal or termination of the contract will be applied upon discovery of misrepresentation of information.

In addition, the bidder must include audited financial statements for the last three fiscal years and also evidence of access to funds stated.

The Contractor should provide proof in the following forms”

1. Bank Statement (s)
2. Letter of Credit (L/C)
3. Bank Reference
4. Any other evidence in support of funding

Y-points

Technical Adequacy (Max – 60points)

Max Score attained from sum of Table 2 (10 point Max), Table 3 (40 points Max) Score and formula 2 (10 point Max).

Technical Specification Submission

Technical Specification Submissions	Total Points = 10
75 - 100%	10
50 -75%	7
40 -50%	5
35-40%	3
Else	0

Table 2 – Points to be gained based on Clarity and completeness of technical Submissions

Technical Evaluation

Technical Suitability	Total Points = 40
Yes	40
No	0

Table 3 – Points to be gained based on evaluation of technical submissions for compliance
Compliance is evaluated against the requirements submitted in the technical evaluation sheets provided.

Formula 2

Delivery Score

$$\text{Delivery Score} = \frac{\text{Minimum Delivery time (Weeks)}}{\text{Bidder's Delivery time (Weeks)}} \times 10$$

Minimum Thresholds

Bidders failing to meet the following criteria will not be evaluated, as they would be deemed unqualified for the award of contract.

1. Minimum X-points of 20
2. Minimum Y-points of 30

NOTES ON EVALUATION

- (a) The Contract would be awarded to the Bidder whose bid is determined to be substantially Responsive to the Bid Document and who has offered the lowest evaluated Bid Price

A penalty of immediate rejection of a bid or termination of contract will be applied upon discovery of misrepresentation of information

Law of Guyana: Procurement Act 2003

Section 39 – Subsection 6 (b)

- (a) The procuring entity may grant a margin of preference not exceeding ten percent to tenders submitted by domestic contractors or for the benefit of tenders for domestically produced goods, provided that such preference is specified in the tender documents. If the lowest evaluated tender was submitted by a foreign tenderer, the evaluating committee will apply the margin of preference to the prices submitted by all foreign tenderers, for evaluation purpose. If, after applying the margin of preference, the lowest evaluated tender was submitted by a domestic tenderer, such tenderer shall be awarded the contract. Otherwise, the foreign tenderer who has submitted the lowest evaluated tender shall be awarded the contract.